



**MERIDIAN**<sup>TM</sup>  
YACHTS

341 SEDAN OWNER'S MANUAL



**Port Engine Serial Number:** \_\_\_\_\_

**Starboard Engine Serial Number:** \_\_\_\_\_

**Hull Identification Number:** \_\_\_\_\_

**Date of Purchase** \_\_\_\_\_

***Hull Identification Number***

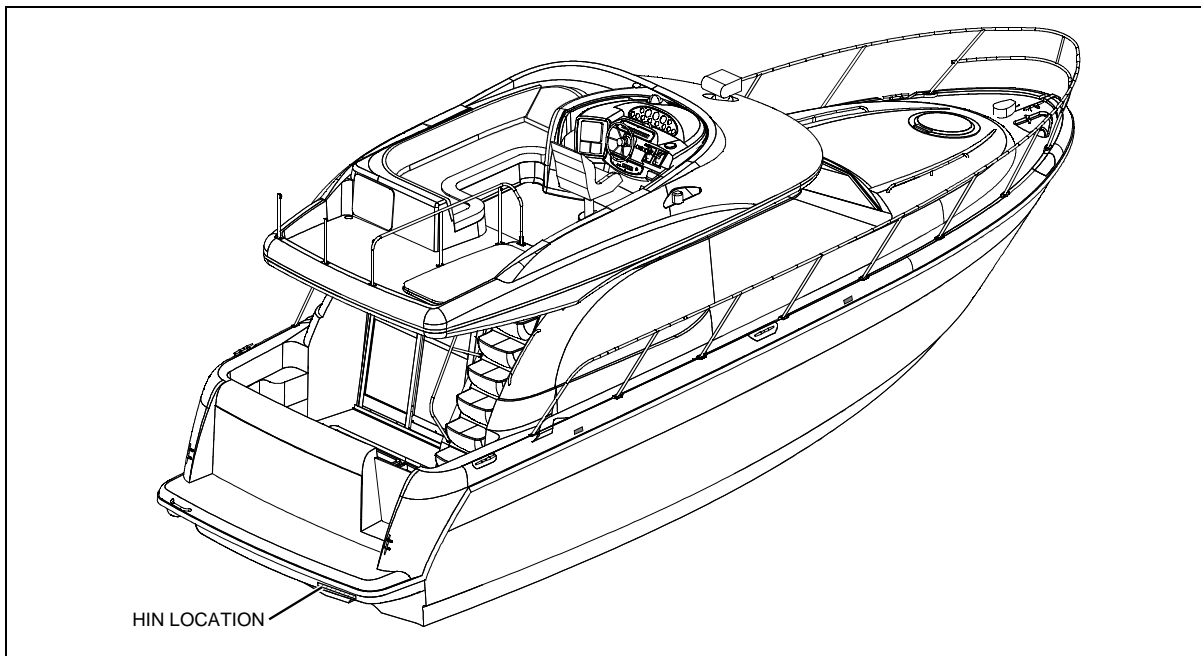

- The Hull Identification Number (HIN) is located on the starboard side of the transom.
- Record the HIN (and the engine serial numbers) in the space provided above.
- Please refer to the HIN for any correspondence or orders.

**© 2003 Meridian Technical Publications. All rights reserved.**

No part of this publication may be reproduced, stored in any retrieval system, or transmitted in any form by any means, electronic, mechanical, photocopying, recording or otherwise, without prior written permission of Meridian.

Printed in the United States of America.

**General Notes**

The material in this document is for information only and is subject to change without notice. While reasonable efforts have been made in the preparation of this document to assure its accuracy, Meridian assumes no liability resulting from errors or omissions in this document, or from the use of information contained herein. Due to our commitment to product improvement, Meridian reserves the right to make changes in the product design, specifications, and equipment at any time without notice or obligation. Illustrations and/or photos may show optional equipment.

All Meridian products meet or exceed USCG (United States Coast Guard) and/or NMMA (National Marine Manufacturer's Association) construction standards. Manufactured with 1,1,1 Trichloroethane, a substance which harms public health and environment during the manufacturing process by destroying ozone in the upper atmosphere.

**Proprietary Rights**

This document discloses subject matter in which Meridian has proprietary rights. The information and design disclosed herein were originated by and are the property of Meridian. Neither receipt nor possession thereof confers or transfers any right to reproduce, copy, alter or disclose the document or any part thereof, any information contained therein, or to construct boats or any item from it, except by written permission from or written agreement with Meridian. This document is to be returned upon request to Meridian.

# CONTENTS

---

## **1 Chapter 1: Welcome Aboard!**

- 1 Dimensions and Tank Capacities
- 1 Layout View
- 1 Dealer Service
- 2 Warranty Information
- 2 Boating Experience
- 2 Engines & Accessories Guidelines
- 2 Engine & Accessories Literature
- 3 Safety Standards
- 3 Qualified Maintenance
- 3 Structural Limitations
- 4 Special Care For Moored Boats
  - 4 *Sacrificial Anodes (Zincs)*
- 5 Boat Lifting
- 6 Carbon Monoxide (CO)
  - 6 *Facts about CO*
  - 7 *Where and How CO Can Accumulate*
  - 7 *How to Protect Yourself and Others From CO*
  - 8 *Trip Checklist*
  - 8 *Monthly Checklist*
  - 8 *Annual Checklist*
  - 8 *Carbon Monoxide Alarm System*
  - 9 *More Information*

## **10 Chapter 2: Locations**

- 10 Exterior Views
  - 10 *Hull Views*
  - 11 *Forward Deck View*
  - 12 *Aft Deck Views*
  - 13 *Helm Stations*
- 14 Component Locations

## **25 Chapter 3: Propulsion & Related Systems**

- 25 Engine
- 26 Exhaust System
- 27 Engine Room Ventilation System
- 28 Fuel System
  - 29 *Fuel Fills & Vents*
  - 30 *Fuel Transfer Pump (If Equipped)*
  - 30 *Fuel Filters*
  - 30 *Anti-siphon Valve (If Equipped)*
- 31 Oil Change System (If Equipped)
- 31 Fire Suppression System (If Equipped)
- 32 Shaft-Transmission Alignment

## **33 Chapter 4: Controls & Gauges**

- 33 Steering
- 33 Rudder Stuffing Gland
- 34 Autopilot (If Equipped)
- 35 Shift/Throttle Controls
  - 35 *Engine Synchronization (If Equipped)*
- 35 Trim Tabs
- 36 Dual Thruster System (If Equipped)
- 37 Gauges
  - 37 *Cleaning Gauges*
  - 37 *Gauge Fogging*
  - 37 *Radio Transmission Interference*
  - 37 *Twin Engine Readings*
  - 37 *Fuel Gauge*
  - 37 *Synchronizer*

## **38 Chapter 5: Navigation & Communication Equipment**

- 38 Compass
- 38 Global Positioning System (GPS) (If Equipped)
- 39 Radar (If Equipped)
- 39 VHF Radio (If Equipped)
- 39 Depth Finder

---

## **40 Chapter 6: Plumbing**

- 40 Bilge Pumps
  - 42 *Autofloat Switches*
- 43 Seawater Systems
  - 43 *Seacocks*
  - 43 *Seawater Strainers*
  - 44 *Raw Water Washdown (If Equipped)*
- 45 Freshwater System
  - 46 *Freshwater System Winterization*
  - 46 *Winterizing the Water Heater*
  - 47 *Water Heater*
  - 48 *Transom Shower*
  - 48 *City Water Inlet*
- 49 Drain Systems
  - 49 *Deck Drains*
  - 50 *Sink Drains*
  - 50 *Shower Drain System*
  - 50 *Sump Box Cleaning*
  - 50 *Sump System Winterization*
- 51 Marine Head with Holding Tank
  - 51 *Winterizing The Marine Head*
  - 52 *Macerator (If Equipped)*
  - 53 *VacuFlush (If Equipped)*

## **54 Chapter 7: Deck Equipment**

- 54 Cleats
- 54 Windlass (If Equipped)
- 55 Canvas

## **56 Chapter 8: Appliances & Entertainment Systems**

- 56 Refrigerator
- 56 Electric Stove (If Equipped)
- 57 Propane Stove (If Equipped)
- 58 Propane System (If Equipped)
- 58 Audio & Visual Equipment
- 59 Dockside Television & Telephone Inlet

## **60 Chapter 9: Lights**

- 60 Care and Maintenance
- 60 Interior & Exterior Lights
- 60 Spotlight (If Equipped)

## **61 Chapter 10: Heating & Air Conditioning**

- 61 Air Conditioning System (If Equipped)
- 62 Electric Heaters (If Equipped)
- 62 Heat Exchanger Cabin Heater (If Equipped)

## **63 Chapter 11: Electrical Systems**

- 64 12-Volt DC System
  - 64 *Batteries*
  - 64 *Fuses and Circuit Breakers*
  - 64 *12-Volt Accessory Outlet*
  - 64 *Battery Switch*
  - 65 *Alternators*
  - 65 *Battery Charger*
- 66 120-Volt AC System
  - 66 *Shore Power*
  - 68 *Connecting To Shore Power*
  - 69 *Generator (If Equipped)*
  - 71 *Inverter Power (If Equipped)*
- 72 Electrical Routings
  - 72 *Deck Electrical Harness*
  - 73 *Command Bridge Harness*
  - 74 *12 Volt DC Electrical System*
  - 74 *Power Inverter (If Equipped)*
  - 75 *Dual Thrusters (If Equipped)*
  - 76 *Battery System*
  - 76 *Bonding Harness*
- 77 Wiring Diagrams
  - 77 *120-Volt AC Electrical System*
  - 78 *12-Volt Auxiliary DC Electrical System*
  - 79 *Command Bridge 12-Volt DC Electrical System*
  - 80 *12-Volt DC Breaker Panel System*
  - 81 *Engine Electrical System*

## **82 Important Records**

## **83 Float Plan**

## Hazard Boxes & Symbols

The hazard boxes and symbols shown below are used throughout this *Manual* to call attention to potentially dangerous situations which could lead to either personal injury or product damage. **Read ALL warnings carefully and follow all safety instructions.**

 **DANGER!**  
This box alerts you to immediate hazards which *WILL* cause severe personal injury or death if the warning is ignored.

 **WARNING!**  
This box alerts you to hazards or unsafe practices which *COULD* result in severe personal injury or death if the warning is ignored.

 **CAUTION!**  
This box alerts you to hazards or unsafe practices which *COULD* result in minor personal injury or cause product or property damage if the warning is ignored.

**NOTICE**  
This box calls attention to installation, operation or maintenance information, which is important to proper operation but is not hazard related.

 FIRE HAZARD!	 EXPLOSION HAZARD!	 NO OPEN FLAME!	 ELECTRICAL HAZARD!	 HOT HAZARD!
--	---	--	---	---

 FALLING HAZARD!	 ROTATING PROPELLER HAZARD!	 RUN BILGE BLOWERS FOR 4 MINUTES!
---	---	---

  
**DANGER**  
CARBON MONOXIDE  
CO POISONING  
HAZARD!

## Chapter 1: Welcome Aboard!

- This *Owner's Manual* provides information about your yacht that is **not** covered in the *Cruiser & Yacht Owner's Manual Supplement*.
- **Before** using your yacht, study this *Owner's Manual*, the *Cruiser & Yacht Owner's Manual Supplement*, and **all** engine and accessory literature carefully.
- Keep this *Owner's Manual* and the *Cruiser & Yacht Owner's Manual Supplement* on your yacht in a secure, yet readily available place.

### Dimensions and Tank Capacities

Overall Length	Bridge Clearance	Beam	Draft (Hull)	Draft (Maximum)	Fuel Capacity (gal.)	Freshwater Capacity (gal.)	Waste Holding Tank Capacity (gal.)
35' 0"	13' 6"	11' 8"	2' 6"	3' 2"	224	92	30

### Layout View

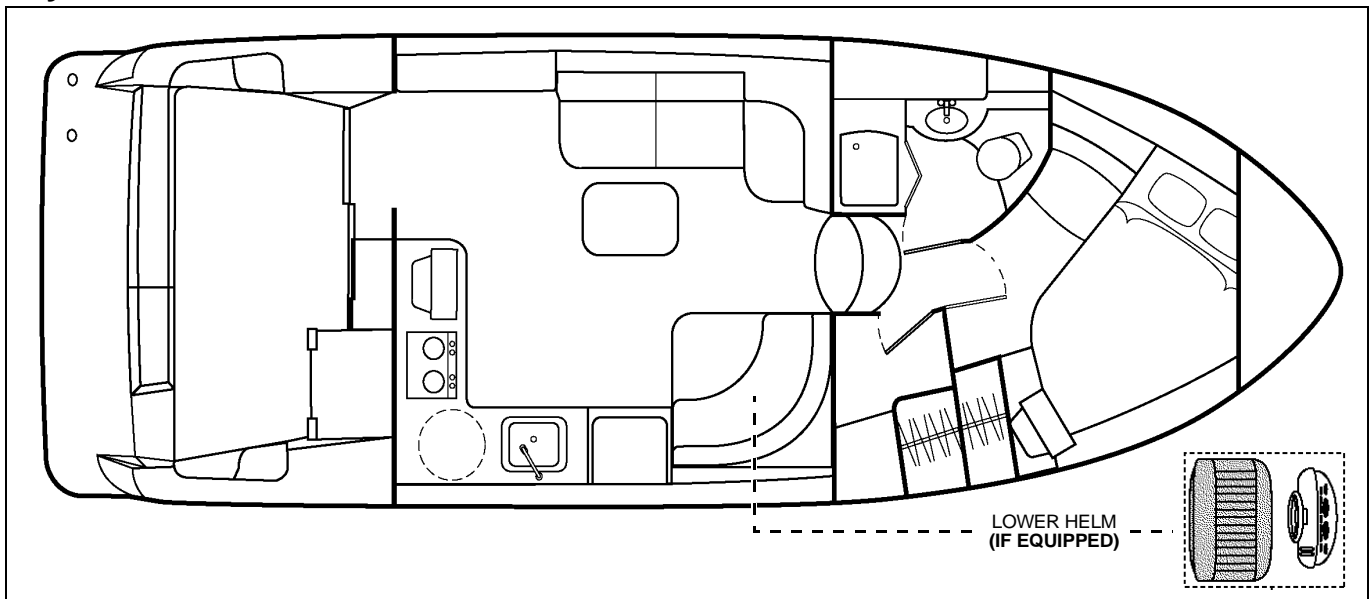

### Dealer Service

- Ask your dealer to explain **all** systems before taking delivery of your yacht.
- Your dealer is your key to service.
- Contact your dealer if you have any questions or problems with your new yacht.
- If your dealer cannot help, call our customer service hotline: 360-403-2198 or send us a FAX: 360-403-1158.
- Buy replacement parts from any authorized Meridian dealer.

## Warranty Information

- Meridian offers an Express Limited Transferable Warranty on each new Meridian purchased through an authorized Meridian dealer.
- A copy of the Express Limited Transferable Warranty was included in your owner's packet.
- If you did **not** receive a copy of the Express Limited Transferable Warranty, please contact your dealer or call 360-403-2198 for a copy.

## Boating Experience

 <b>WARNING!</b>
<p><b><i>CONTROL HAZARD!</i></b></p> <p><b>A qualified operator <i>must</i> be in control of the yacht at <i>all</i> times. <i>DO NOT</i> operate your yacht while under the influence of alcohol or drugs.</b></p>

If this is your first yacht or if you are changing to a type of yacht you are **not** familiar with, obtain handling and operating experience **before** assuming command of the yacht.

Take one of the boating safety classes offered by the U.S. Power Squadrons or the U.S. Coast Guard Auxiliary. For more course information, including dates and locations of upcoming classes, contact the organizations directly:

- U.S. Power Squadrons: 1-888-FOR-USPS (1-888-367-8777) or on the Internet at: <http://www.usps.org>
- U.S. Coast Guard Auxiliary: 1-800-368-5647 or on the Internet at: <http://www.cgaux.org>

Outside the United States, your selling dealer, national sailing federation or local boat club can advise you of local sea schools or competent instructors.

## Engines & Accessories Guidelines

<b>NOTICE</b>
<p><b>When storing your yacht please refer to your engine's operation and maintenance manuals.</b></p>

- Your yacht's engines and accessories were selected to provide optimum performance and service.
- Installing different engines or other accessories may cause unwanted handling characteristics.
- Should you choose to install different engines or to add accessories that will affect the yacht's running trim, have an experienced marine technician perform a safety inspection and handling test **before** operating your yacht again.
- **Certain modifications to your yacht will result in the cancellation of your warranty protection. Always check with your dealer *before* making any modifications to your yacht.**

## Engine & Accessories Literature

- The engines and accessories installed on your boat come with their own operation and maintenance manuals.
- Read and understand these manuals **before** using the engines and accessories.
- Unless noted otherwise, **all** engine and accessory literature referred to in this *Owner's Manual* is included in your owner's packet.



## Safety Standards

**⚠ DANGER!**





***FALLING and ROTATING PROPELLER HAZARD!***

**NEVER** allow anyone to ride on parts of the yacht *not* designed for such use.

- Sitting on seat backs, lounging on the forward deck, bow riding, gunwale riding or occupying the transom platform while underway is especially hazardous and will cause personal injury or death.

**⚠ DANGER!**





***ROTATING PROPELLER and CARBON MONOXIDE POISONING HAZARD!***

- **NEVER** allow anyone to occupy, or hang from, the back deck or swim platform while the engine(s) are running.
- Teak surfing, dragging, or water skiing within 20 feet of a moving watercraft can be fatal.

**⚠ DANGER!**

***PERSONAL SAFETY HAZARD!***

**ALWAYS** secure the anchor and other loose objects *before* getting underway. The anchor and other items that are *not* properly secured can come loose when the yacht is moving and cause personal injury or death.

Your yacht's mechanical and electrical systems were designed to meet safety standards in effect at the time it was built. Some of these standards were mandated by law, *all* of them were designed to insure your safety, and the safety of other people, vessels and property.

**In addition to this *Owner's Manual*, please read the *Cruiser & Yacht Owner's Manual Supplement* and *all* accessory instructions for important safety standards and hazard information.**

## Qualified Maintenance

**⚠ WARNING!**

**To maintain the integrity and safety of your yacht, allow only qualified personnel to perform maintenance on, or in any way modify: The steering system, propulsion system, engine control system, fuel system, environmental control system, electrical system or navigational system.**

- Failure to maintain your yacht's systems (listed in the warning above) as designed could violate the laws in your jurisdiction and could expose you and other people to the danger of bodily injury or accidental death.
- Follow the instructions provided in the *Cruiser & Yacht Owner's Manual Supplement*, this *Owner's Manual*, the engine owner's manual and *all* accessory literature.

## Structural Limitations

The command bridge is designed to be lightweight for proper yacht balance. The load limit for this platform is 30 pounds per square foot, evenly distributed.

## Special Care For Moored Boats

### NOTICE

- To help seal the hull bottom and reduce the possibility of gelcoat blistering on moored boats, apply an epoxy barrier coating. The barrier coating should be covered with several coats of anti-fouling paint.
- Many states regulate the chemical content of bottom paints in order to meet environmental standards. Check with your local dealer about recommended bottom paints, and about the laws in effect in your area.

- Whether moored in saltwater or freshwater, your yacht *will* collect marine growth on its hull bottom.
- This will detract from the yacht's beauty, greatly affect its performance and may damage the gelcoat.
- There are two methods of slowing marine growth:
  1. Periodically haul the yacht out of the water and scrub the hull bottom with a bristle brush and a solution of soap and water.
  2. Occasionally re-paint the hull below the waterline with a good grade of anti-fouling paint.

### Sacrificial Anodes (Zincs)

### NOTICE

*Do not* paint between the zinc and the metal surface it contacts and *do not* paint over the zincs.

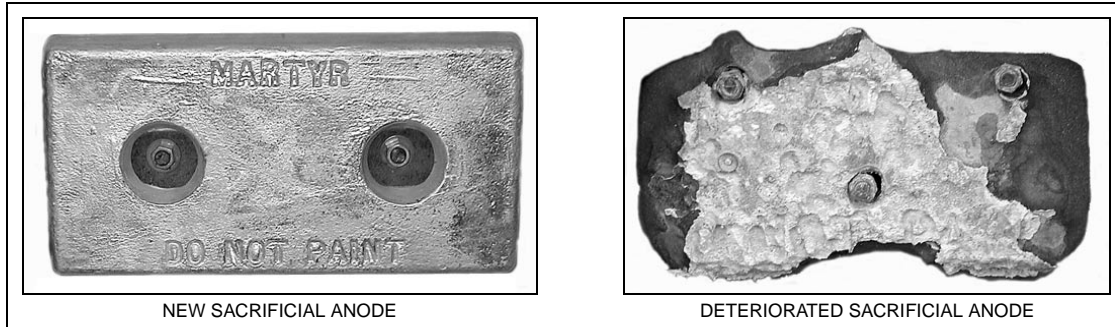

Your yacht features sacrificial anodes (zincs) to protect underwater metal parts from excessive deterioration. Check the zincs regularly and replace them if they have deteriorated more than 70%.

There are many factors that affect the rate at which the zincs deteriorate, including:

- Water temperature
- Salinity
- Water pollution

Stray electrical current from the yacht or dock may cause complete deterioration in just a few weeks. If there is rapid zinc deterioration, measure the electrolytic corrosion around your yacht with a corrosion test meter. If the zincs are *not* bonded correctly, they *will not* provide protection.

## Boat Lifting

### ! WARNING!

**PERSONAL INJURY and /or PRODUCT OR PROPERTY DAMAGE HAZARD!**

- Lifting slings may slip on the hull.
- Avoid serious injury or death by securing the lifting slings together *before* lifting.

### ! WARNING!

**PERSONAL INJURY and /or PRODUCT OR PROPERTY DAMAGE HAZARD!**

- **NEVER** lift the yacht using the bow and stern eyes.

### ! CAUTION!

**PRODUCT or PROPERTY DAMAGE HAZARD!**

- When lifting any yacht, *always* use a spreader bar. The spreader bar *must* be equal to the width of the yacht at each lifting point.

- *Always* follow the lift equipment's instructions and requirements.
- Water in the bilge can shift and change the balance of the load.
- If water is present in the bilge, pump or drain the water out of the bilge areas *before* lifting your yacht.
- When lifting your yacht, always position the lifting slings at the port and starboard, lifting sling label positions, as shown in the illustration on the right.

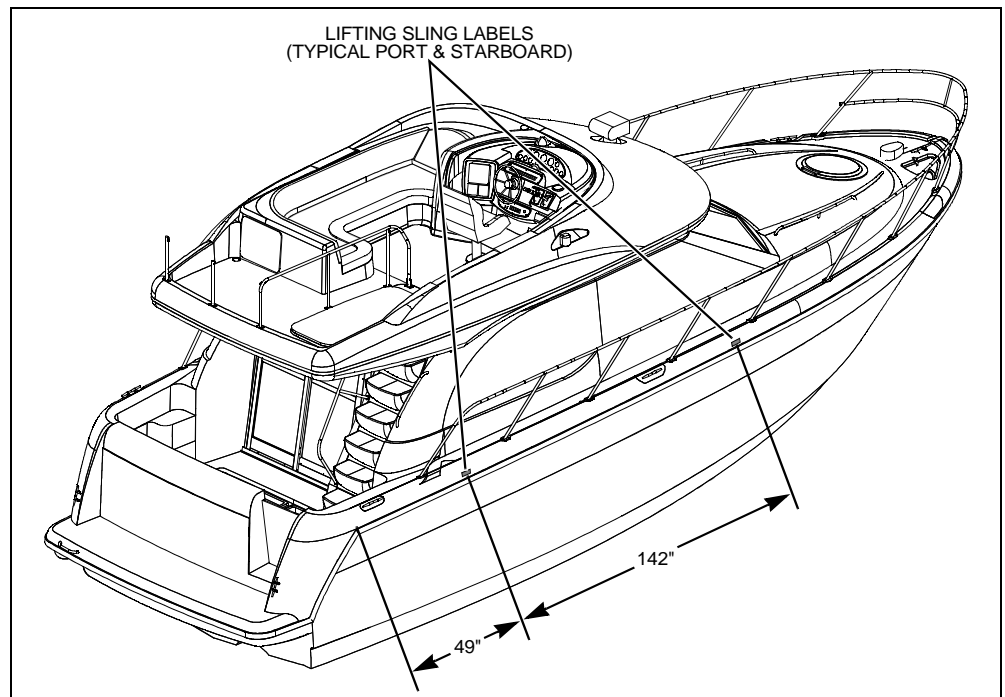

## Carbon Monoxide (CO)

<b>⚠ DANGER!</b>	
	<ul style="list-style-type: none"> <li>• Carbon monoxide gas (CO) is colorless, odorless, tasteless, and extremely dangerous.</li> <li>• All engines, generators, and fuel burning appliances produce CO as exhaust.</li> <li>• Prolonged exposure to low concentrations or very quick exposure to high concentrations <i>will</i> cause BRAIN DAMAGE or DEATH.</li> <li>• Teak surfing, dragging, or water skiing within 20 feet of a moving watercraft can be fatal.</li> </ul>

### ***Facts about CO***

- CO poisoning causes a significant number of boating deaths each year.
- Called the "silent killer", CO is an extremely toxic, colorless, odorless and tasteless gas.
- CO can harm or even kill you inside or outside your yacht.
- CO can affect you whether you're underway, moored, or anchored.
- CO symptoms are similar to seasickness or alcohol intoxication.
- CO can make you sick in seconds. In high enough concentrations, even a few breaths can be fatal.
- Breathing CO blocks the ability of your blood to carry oxygen.
- The effects are cumulative, even low levels of exposure can result in injury or death.

### ***Factors That Increase the Effects of CO Poisoning***

- Age
- Smokers or people exposed to high concentrations of cigarette smoke
- Consumption of alcohol
- Lung disorders
- Heart problems
- Pregnancy

## Where and How CO Can Accumulate

### Stationary Conditions That Increase CO Accumulations Include:

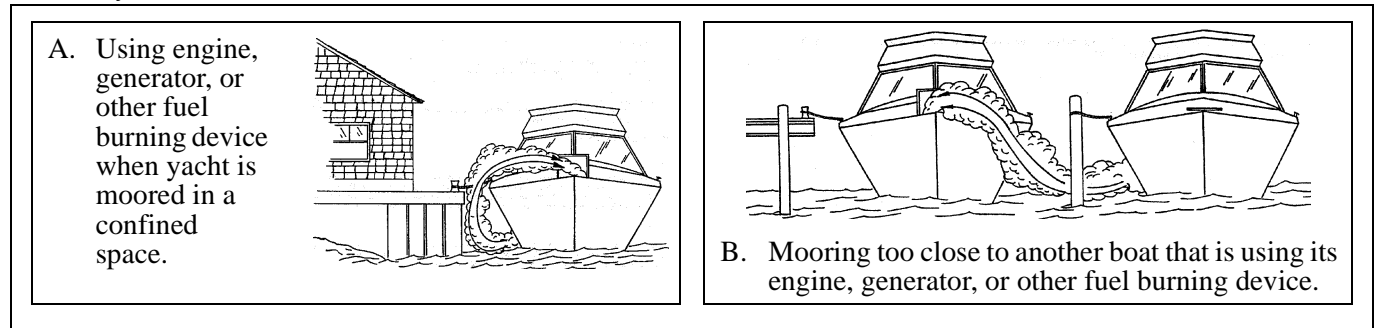

#### To correct stationary situations A and/or B:

- **Close all** windows, portlights and hatches.
- If possible, move your yacht away from source of CO.

### Running Conditions That Increase CO Accumulations Include:

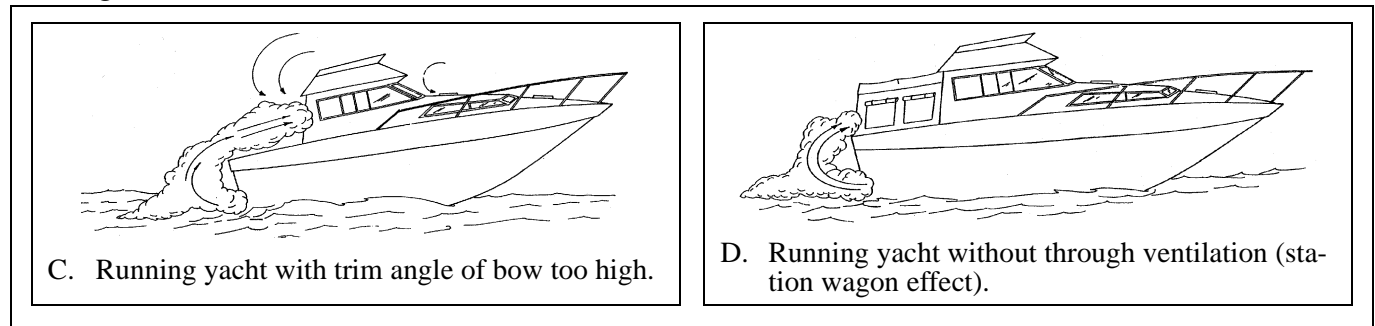

#### To correct running situations C and/or D:

- Trim bow down.
- **Open** windows and canvas.
- When possible, run yacht so that prevailing winds help dissipate exhaust.

## How to Protect Yourself and Others From CO

- Know where and how CO may accumulate in and around your yacht (see above).
- Maintain fresh air circulation throughout the yacht at **all** times.
- Know where your engine and generator exhaust outlets are located and keep everyone away from these areas.
- **Never** sit on, or hang onto, the back deck or swim platform while the engine(s) are running.
- **Never** enter the areas under swim platforms where exhaust outlets are located.
- Although CO can be present without the smell of exhaust fumes, if exhaust fumes are detected on the yacht, take **immediate** action to dissipate these fumes.
- Treat symptoms of seasickness as possible CO poisoning. Get the person into fresh air **immediately**. Seek medical attention—unless you're sure it's not CO.
- Install and maintain CO alarms inside your yacht. **Do not** ignore any alarm. Replace alarms as recommended by the alarm manufacturer.
- Follow the checklists provided on the next page.
- Get a Vessel Safety Check.

For information on how to get a free VESSEL SAFETY CHECK, visit [www.vesselsafetycheck.org](http://www.vesselsafetycheck.org) or contact your local U.S. Coast Guard Auxiliary or United States Power Squadrons®.

- U.S. Coast Guard Auxiliary: 1-800-368-5647 or on the Internet at: <http://www.cgaux.org>
- U.S. Power Squadrons: 1-888-FOR-USPS (1-888-367-8777) or on the Internet at: <http://www.usps.org>

### Trip Checklist

- Make sure you know where the exhaust outlets are located on your yacht.
- Educate *all* passengers about the symptoms of CO poisoning and where CO may accumulate.
- When docked, or rafted with another boat, be aware of exhaust emissions from the other boat.
- Confirm that water flows from the exhaust outlet when the engines and generator are started.
- Listen for any change in exhaust sound, which could indicate an exhaust component failure.
- Test the operation of each CO alarm by pressing the test button.

### Monthly Checklist



- Make sure *all* exhaust clamps are in place and secure.
- Look for exhaust leaking from exhaust system components. Signs include rust and/or black streaking, water leaks, or corroded or cracked fittings.
- Inspect rubber exhaust hoses for burned, cracked, or deteriorated sections. *All* rubber hoses should be pliable and free of kinks.

### Annual Checklist

#### Have a Qualified Marine Technician:

- Replace exhaust hoses if cracking, charring, or deterioration is found.
- Ensure that your engines and generators are properly tuned, and well maintained.
- Inspect each water pump impeller and the water pump housing. Replace if worn. Make sure cooling systems are in working condition.
- Inspect *all* metal exhaust parts for cracking, rusting, leaking, or loosening and check the cylinder head gasket, exhaust manifold, water injection elbow, and the threaded adapter nipple between the manifold and the elbow.
- Clean, inspect, and confirm proper operation of the generator cooling water anti-siphon valve (if equipped).

### Carbon Monoxide Alarm System

 <b>DANGER!</b>	
	<p style="text-align: center;"><b><i>CARBON MONOXIDE POISONING HAZARD!</i></b></p> <ul style="list-style-type: none"> <li>• The house battery switch <i>must</i> be in the <i>On</i> position for the CO Monitors to work.</li> <li>• If your yacht will be unattended for an extended period of time, turn <i>Off</i> the house battery or the CO Monitors <i>will</i> drain the house battery.</li> </ul>

<b>NOTICE</b>
<p><b>The stereo memory and CO monitor(s) place a small, but constant drain on the battery. If your yacht will be unattended for an extended amount of time, plug into shore power with the battery charger turned on, or disconnect the battery if shore power is <i>not</i> an option.</b></p>

- Your yacht features a carbon monoxide (CO) alarm system.
- ***Do not*** disconnect the alarm system.
- Read and understand the manufacturer's instructions for your CO alarm system. If you did ***not*** receive an instruction manual, call (800) 383-0269 and one will be mailed to you.

If your yacht is ***not*** equipped with a carbon monoxide alarm, consider purchasing one from your dealer or marine supply store.

**More Information**

For more information about how you can prevent carbon monoxide poisoning on recreational boats and other ways to boat more safely, contact:

United States Coast Guard  
Office of Boating Safety (G-OPB-3)  
2100 Second Street SW  
Washington, DC 20593  
[www.uscgboating.org](http://www.uscgboating.org)  
1-800-368-5647

National Marine Manufacturers  
Association (NMMA)  
200 East Randolph Drive  
Suite 5100  
Chicago, IL 60601-9301  
[www.nmma.org](http://www.nmma.org)  
312-946-6200

American Boat & Yacht Council, Inc.  
(ABYC)  
3069 Solomon's Island Road  
Edgewater, MD 21037-1416  
[www.abycinc.org](http://www.abycinc.org)  
410-956-1050

For information on how to get a free VESSEL SAFETY CHECK, visit [www.vesselsafetycheck.org](http://www.vesselsafetycheck.org) or contact your local U.S. Coast Guard Auxiliary or United States Power Squadrons®.

- U.S. Coast Guard Auxiliary: 1-800-368-5647 or on the Internet at: <http://www.cgaux.org>
- U.S. Power Squadrons: 1-888-FOR-USPS (1-888-367-8777) or on the Internet at: <http://www.usps.org>

# Chapter 2: Locations

## Exterior Views

### Hull Views

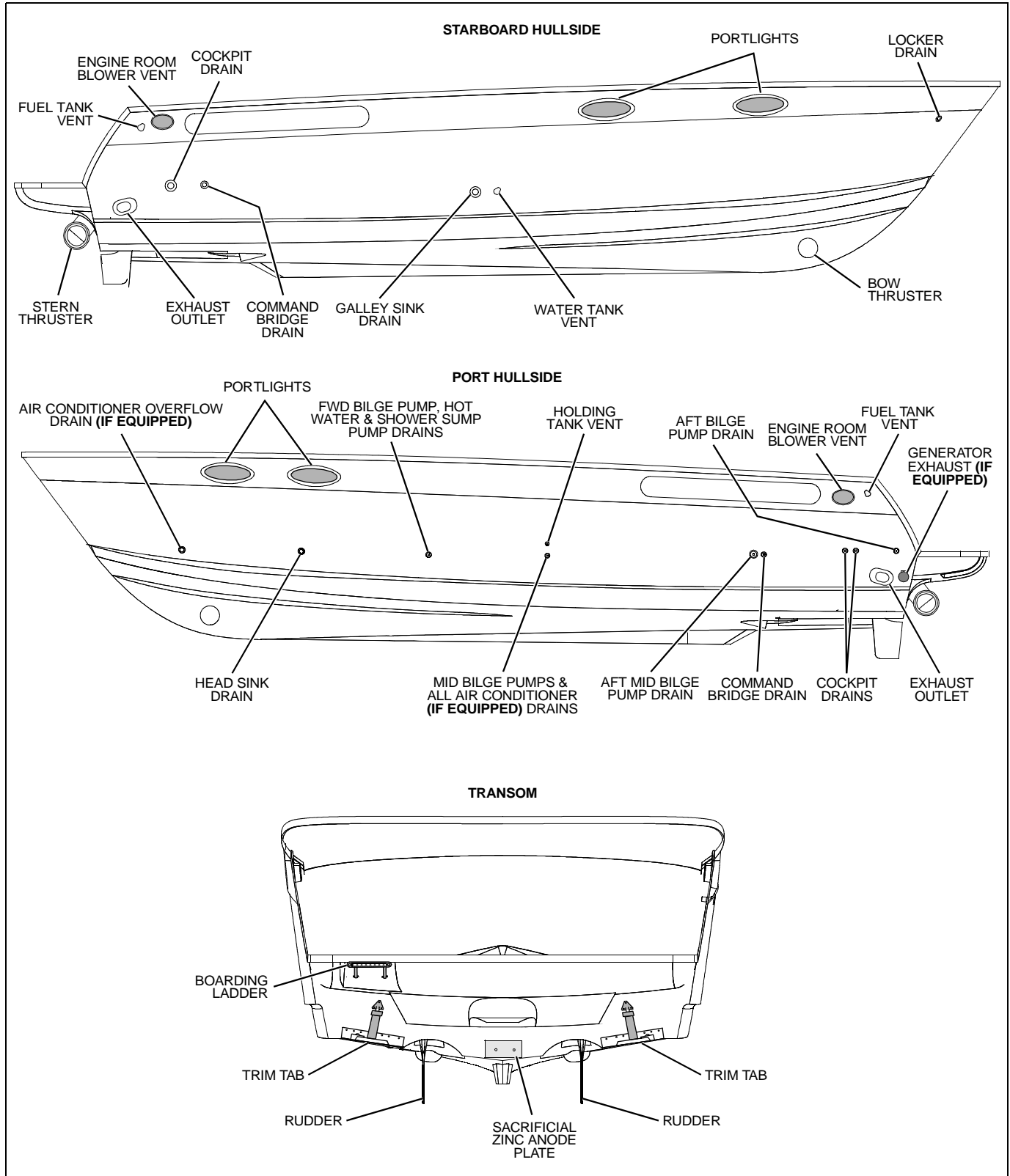



**Forward Deck View**

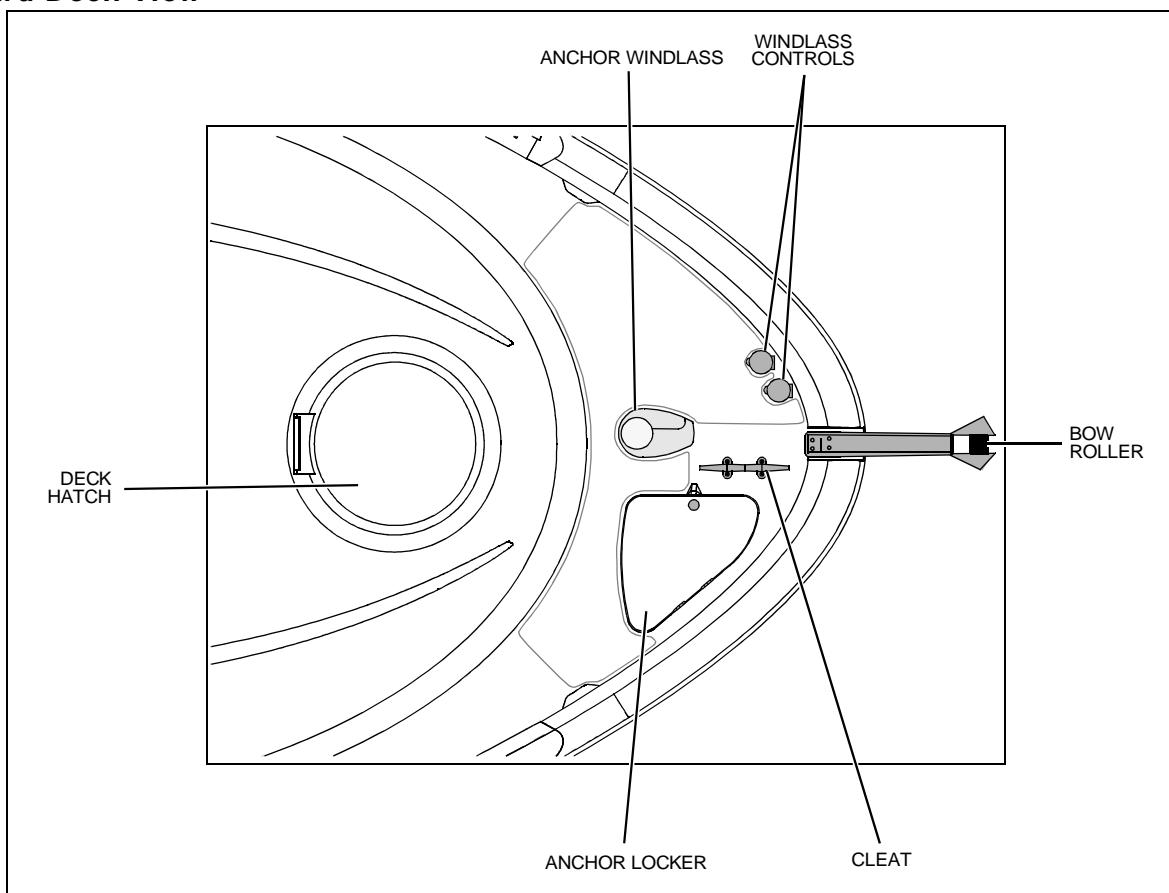

### Aft Deck Views

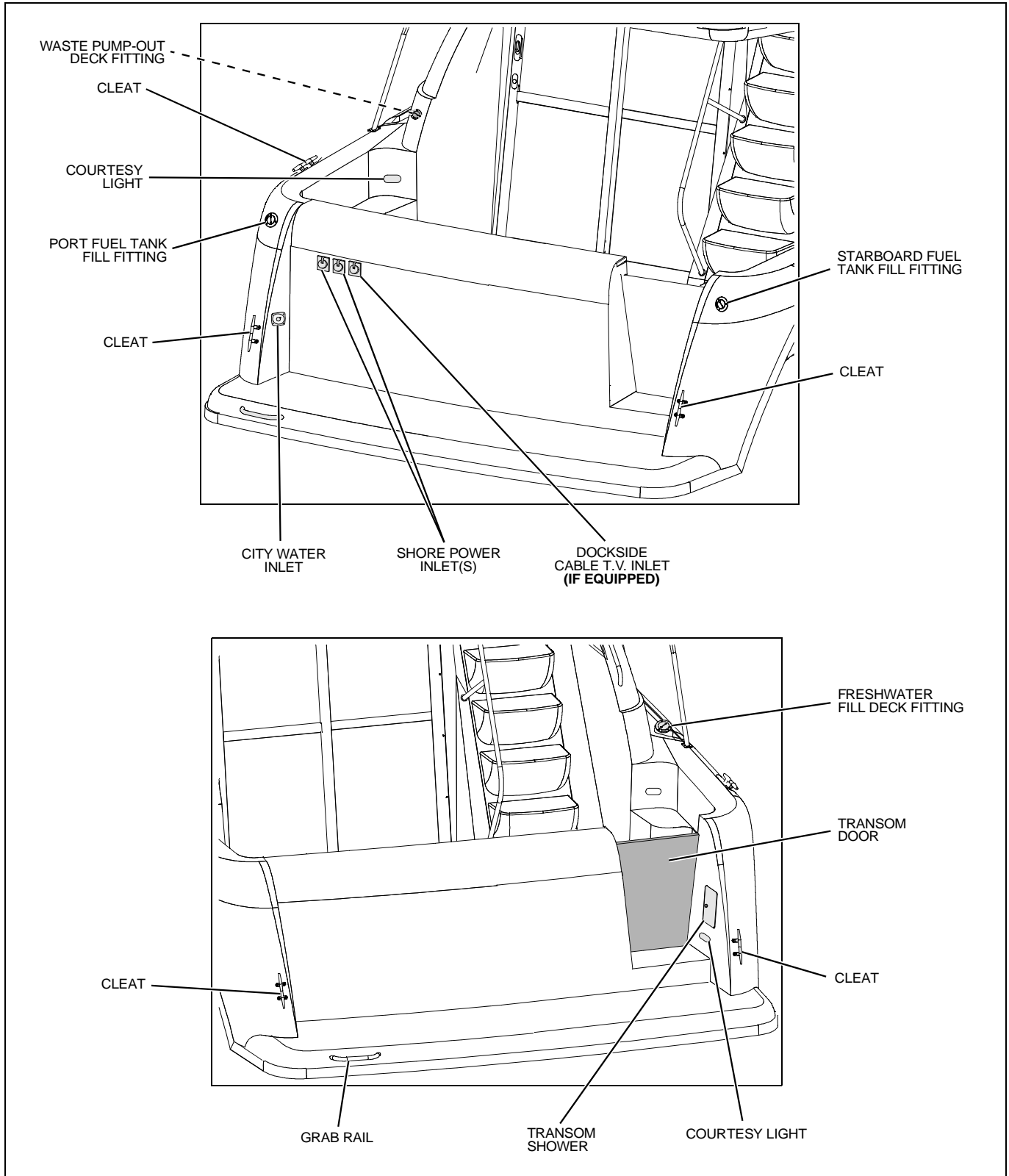

## Helm Stations

### Upper Helm Station

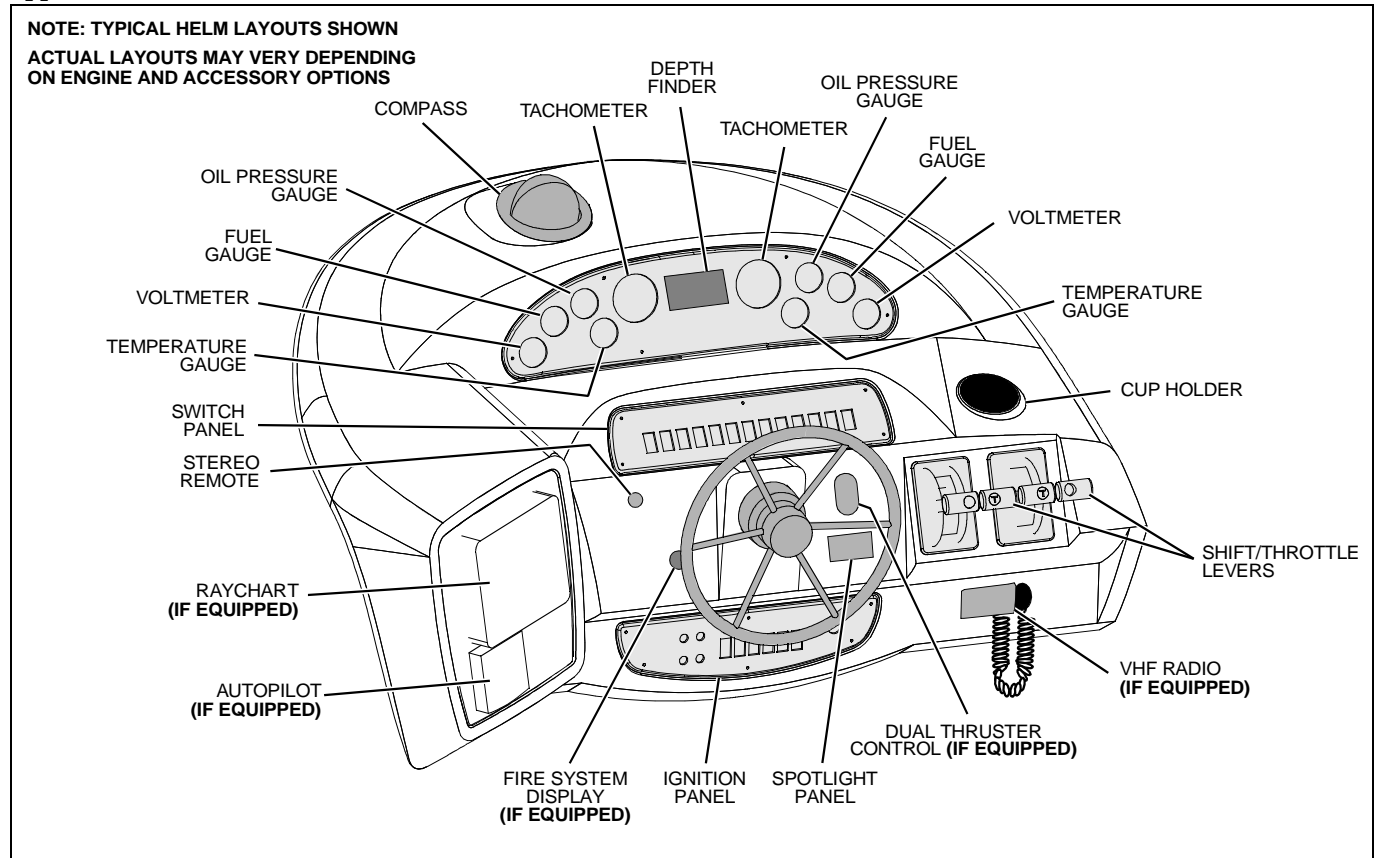

### Lower Helm Station (If Equipped)

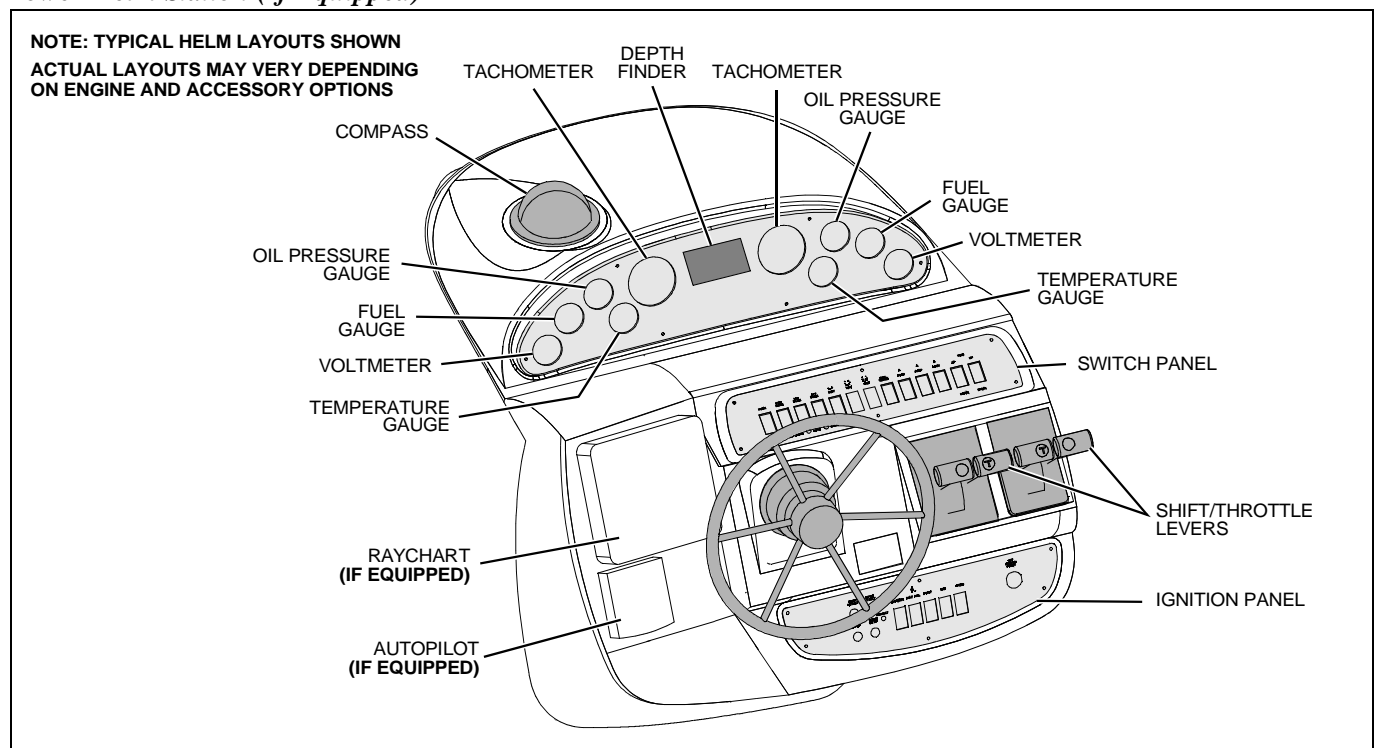

## Component Locations

### 12-Volt Accessory Outlet:

At the helm on the dash ignition panel.

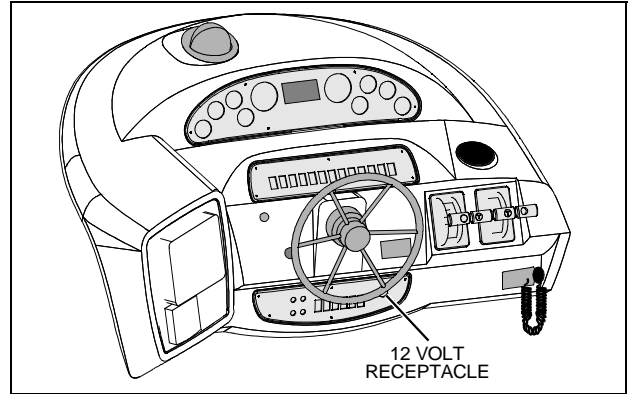

### Air Conditioner Seawater Intake Seacock:

Access is through the floor hatch in the salon, forward of the engine, on the starboard side.

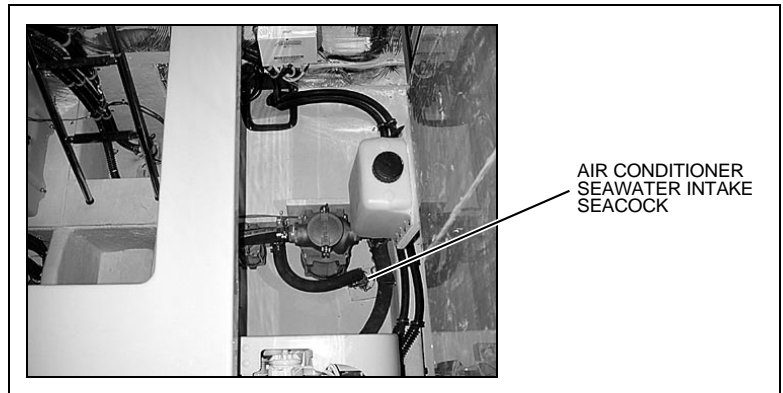

### Air Conditioner Unit:

Access is through the storage locker, under the V-berth mattress.

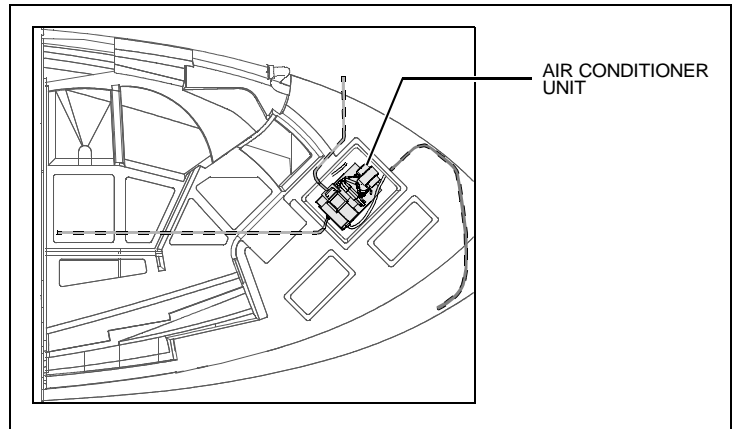

### Batteries:

In the aft machinery room, on the port and starboard sides.

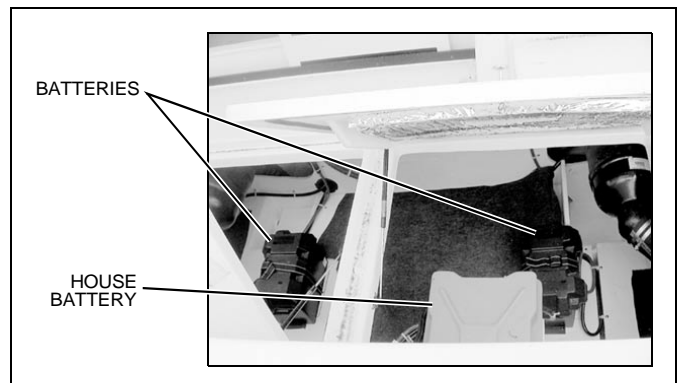

**Battery Charger:**

In the utility room. Access is through the aft wall cut-out in the mid-berth.

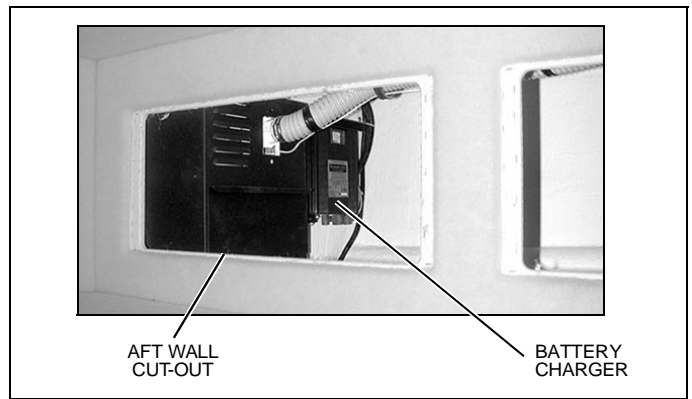

**Battery Switches:**

Inside the AC/DC cabinet on the port side of the salon.

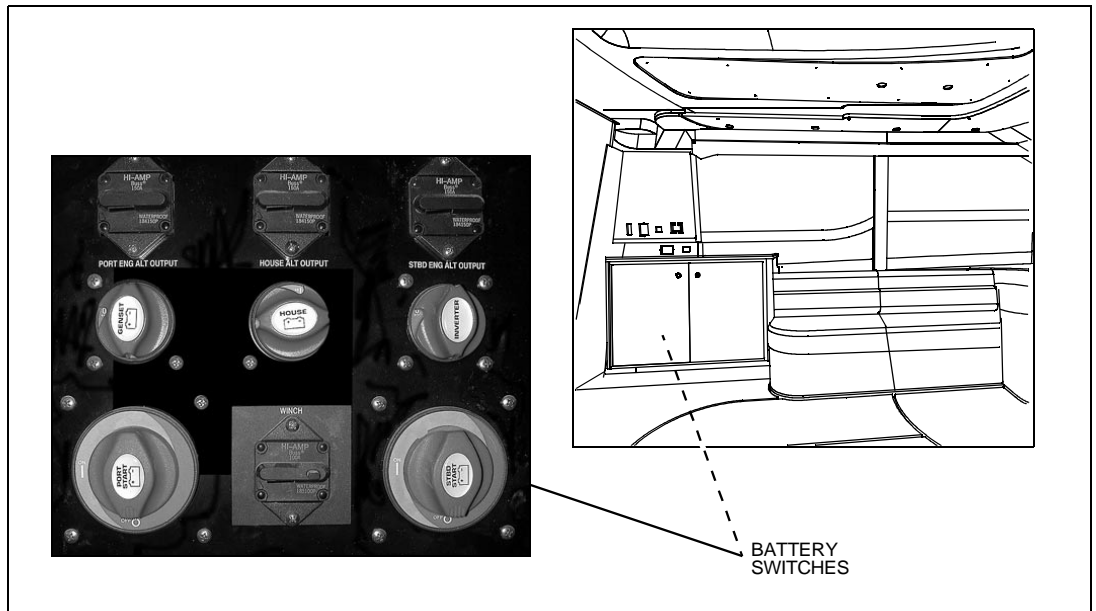

**Bilge Pump - Aft:**

In the aft machinery room.

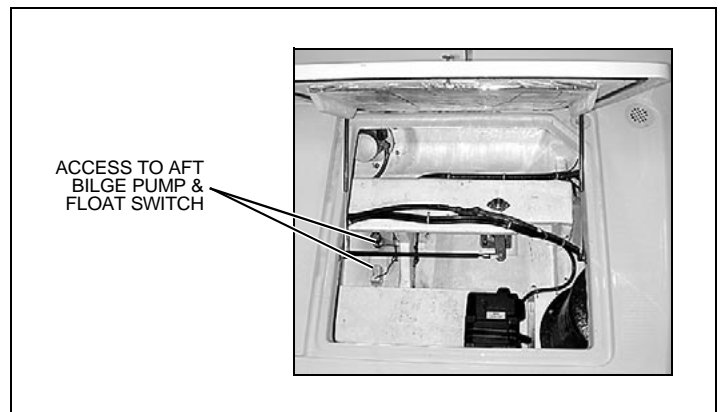

**Bilge Pump - Mid-Aft:**

Access is through the floor hatch in the salon area.

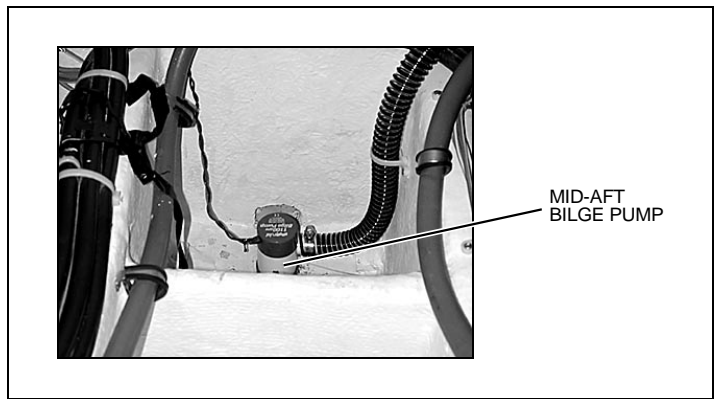

**Bilge Pump - Mid-Forward:**

In the floor hatch in the salon area, in the engine room.

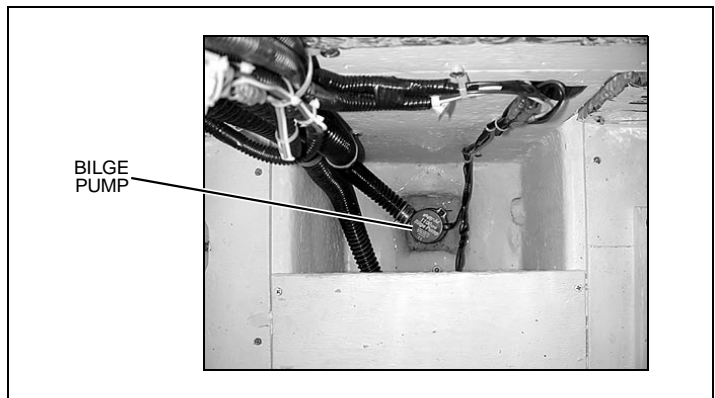

**Bilge Pumps and Float Switch - Forward:**

Access is through the bottom step in the hallway.

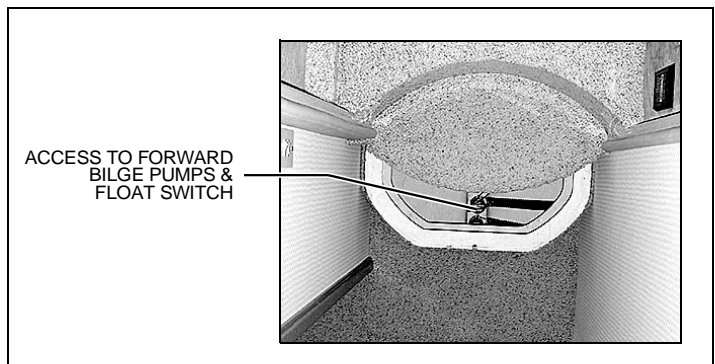

**Carbon Monoxide Detectors (3 total):**

One in the aft berth, on the ceiling. One in the V-berth, on the ceiling. One in the cabin under the windshield.

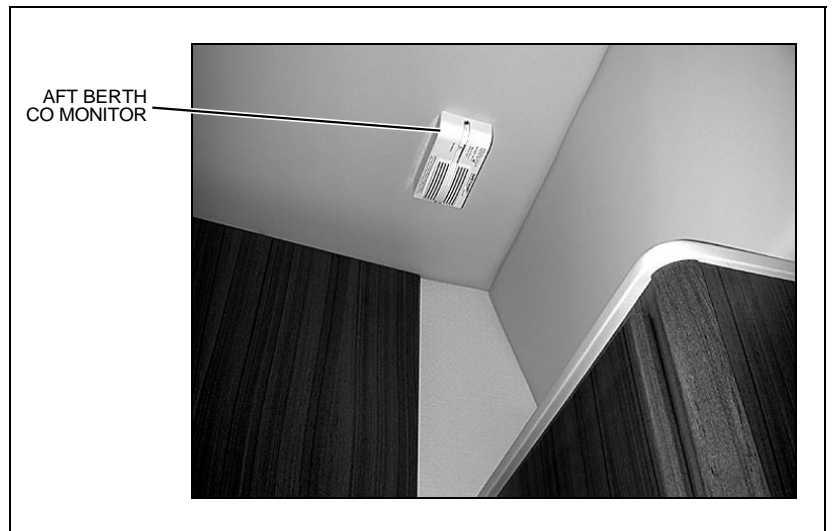

**DC Circuit Breakers:**

In the cabin, on the port side, in the cabinet near the entry door.

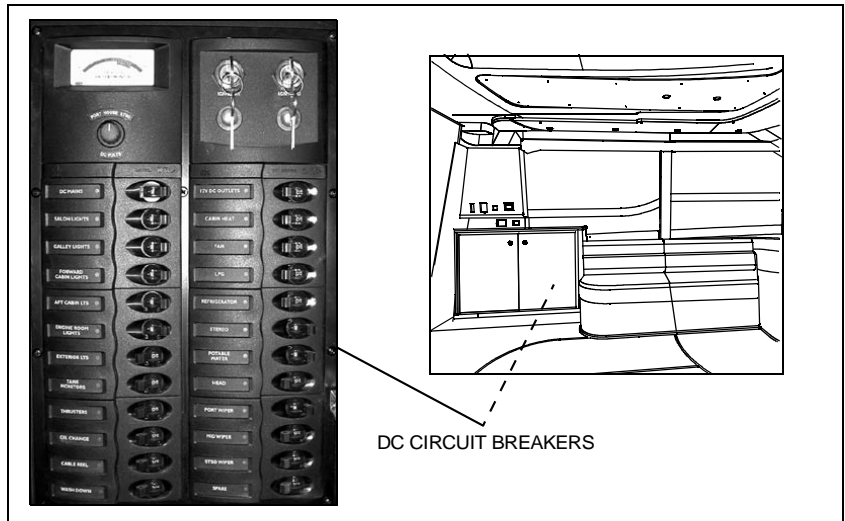

**Depth Sounder Thru-hull Transducer:**

In the engine room on the starboard side. Access is through the starboard salon floor hatch.

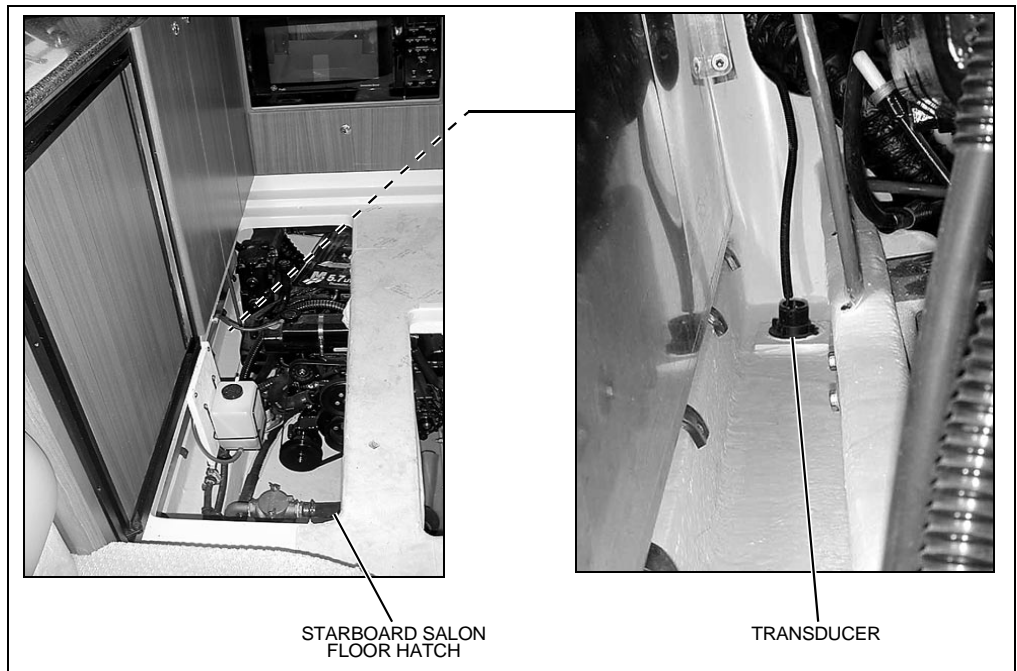

**Engine Circuit Breaker:**

One on each engine.

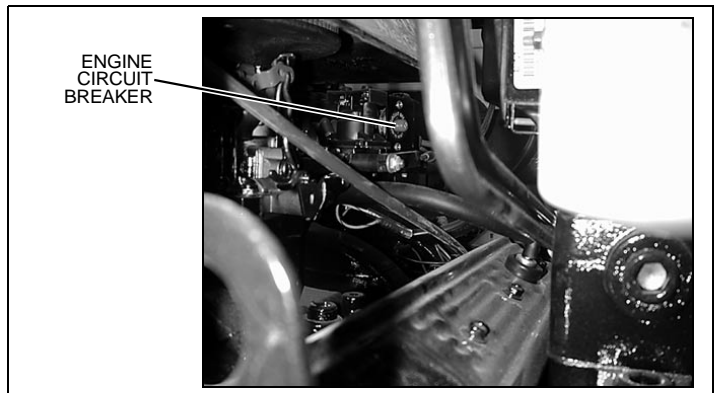



**Freshwater Fill:**

On the starboard deck at the aft end of the deck trail.

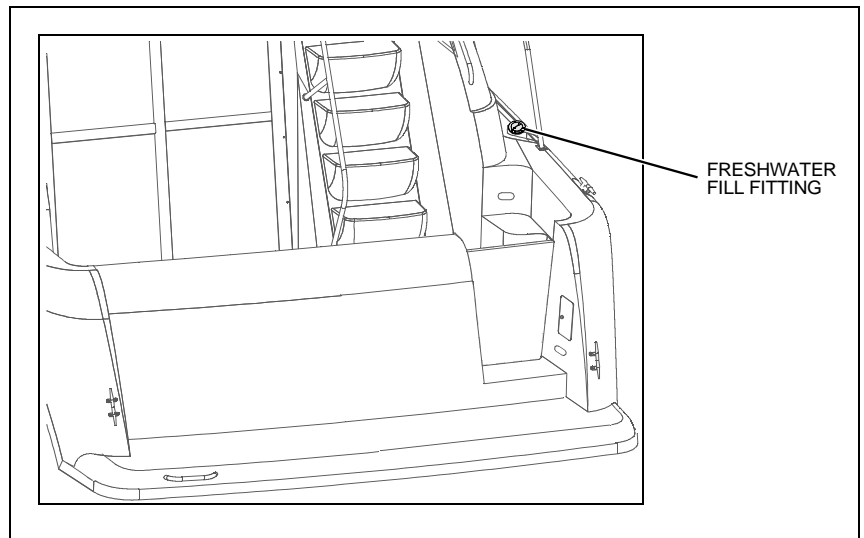
**Freshwater Tank:**

Access is through the hatches, under the mid-berth mattress.

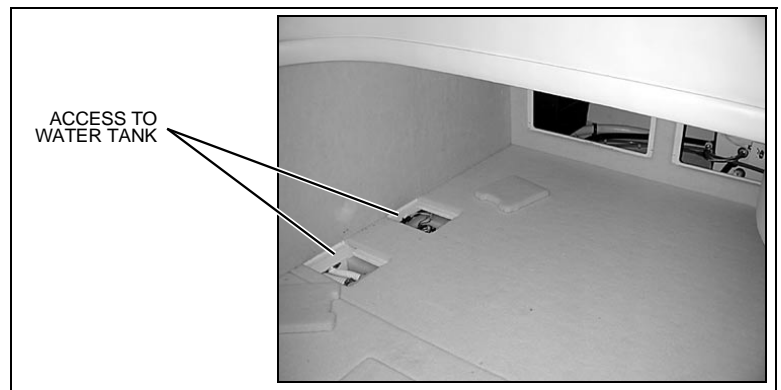
**Fuel Fills:**

On the port and starboard aft corners of the deck.

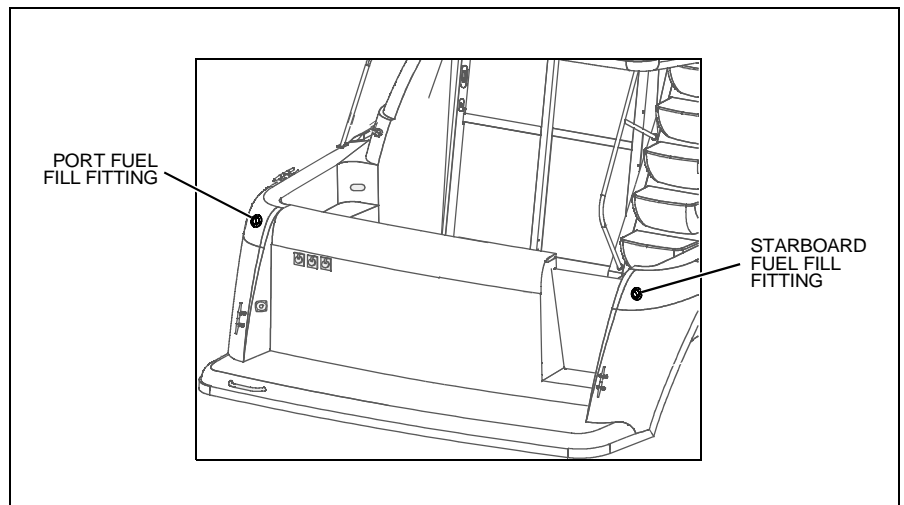

**Fuel Tanks:**

In the engine room; one is on the port side and the other is on the starboard side.

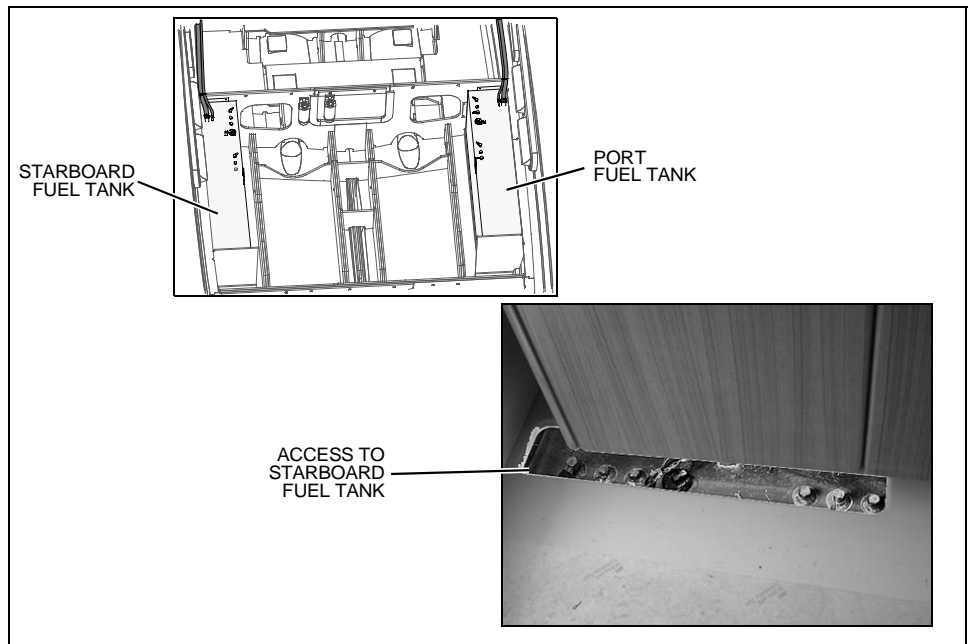

**Generator:**

In the aft machinery room.

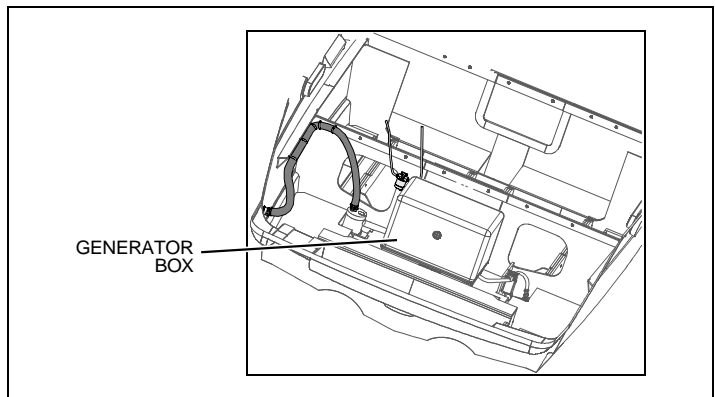

**Generator Pickup:**

In the aft machinery room, on the starboard side.

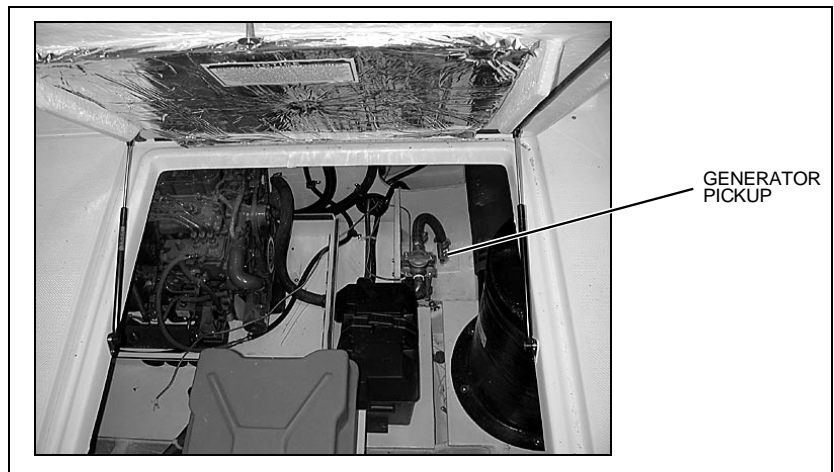

**Inverter:**

Access is through the mid-berth aft wall cut-out.

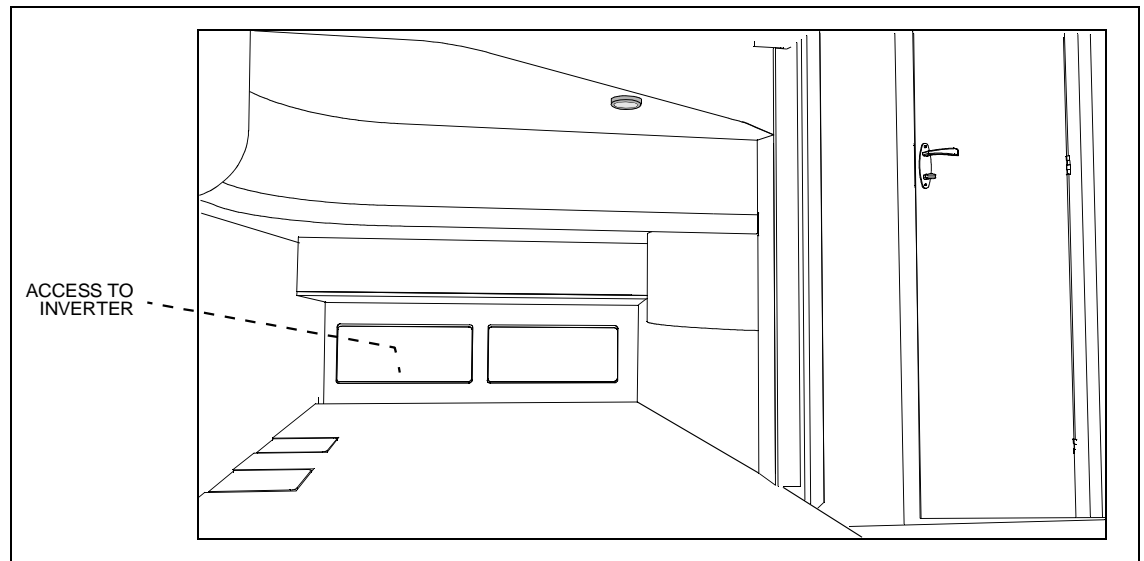
**Macerator Underwater Discharge Seacock:**

On the port side of the engine room. Access is through the floor hatch in the salon.



**Marine Head (Electric) Seacock:**

In the utility room. Access is through the aft wall cut-out in the mid-berth

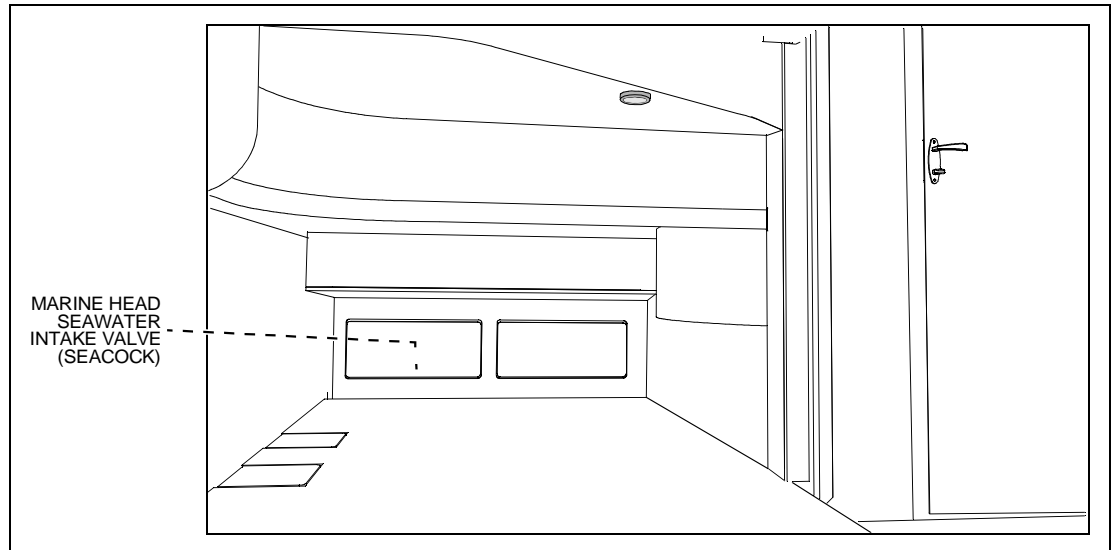

**Propane Tank:**

On the command bridge, inside the aft storage locker.

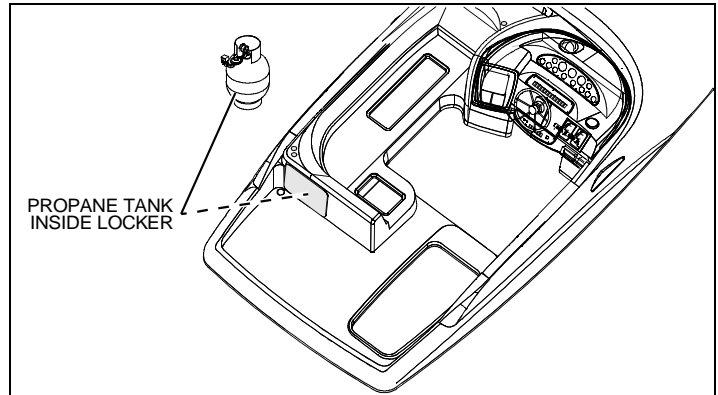

**Wall Vacuum Unit:**

In the utility room. Access is through the aft wall cut-out in the mid-berth.

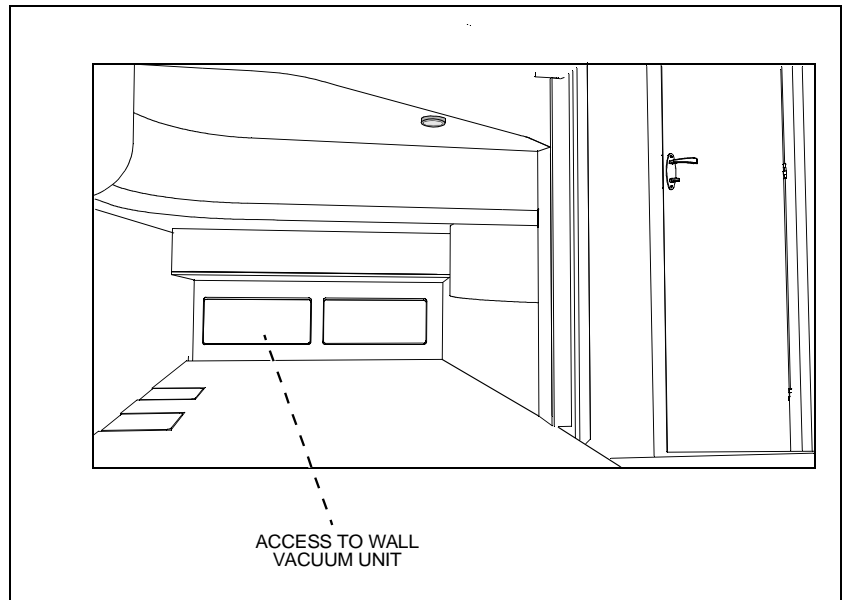

**Waste Holding Tank:**

On the port side of the engine room. Access is through the port side floor hatch in the salon.

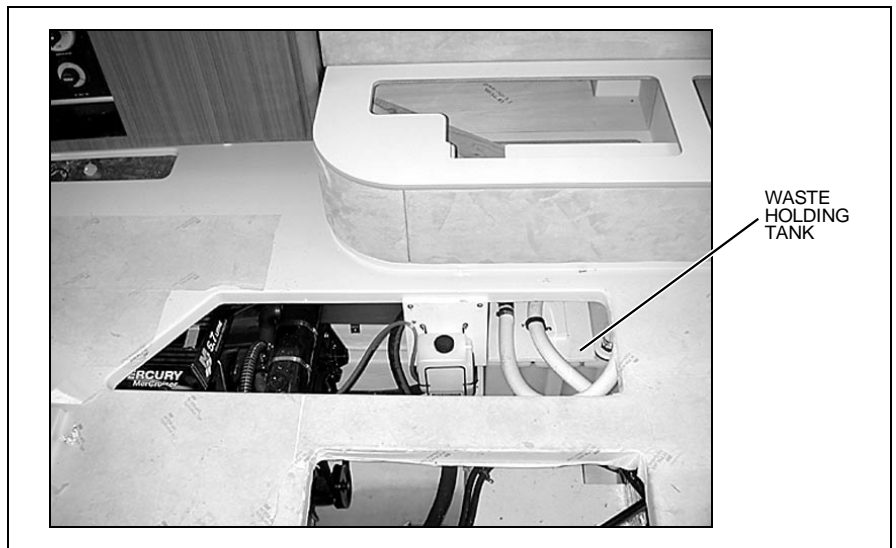
**Water Heater:**

In the utility room. Access is through the forward wall cut-out in the mid-berth.

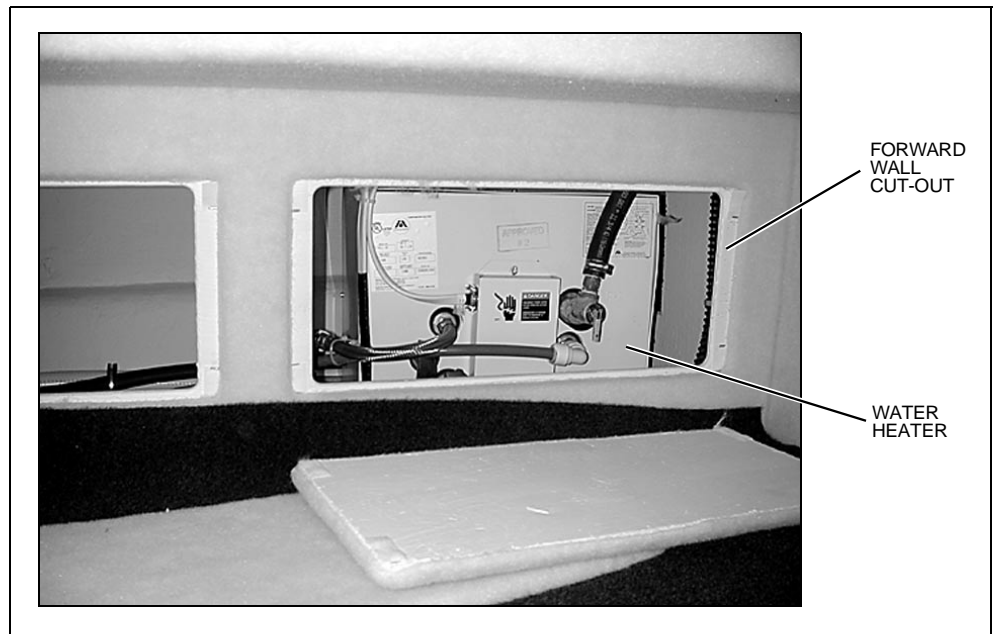

**Water Pump:**

In the utility room. Access is through the forward wall cut-out in the mid-berth.

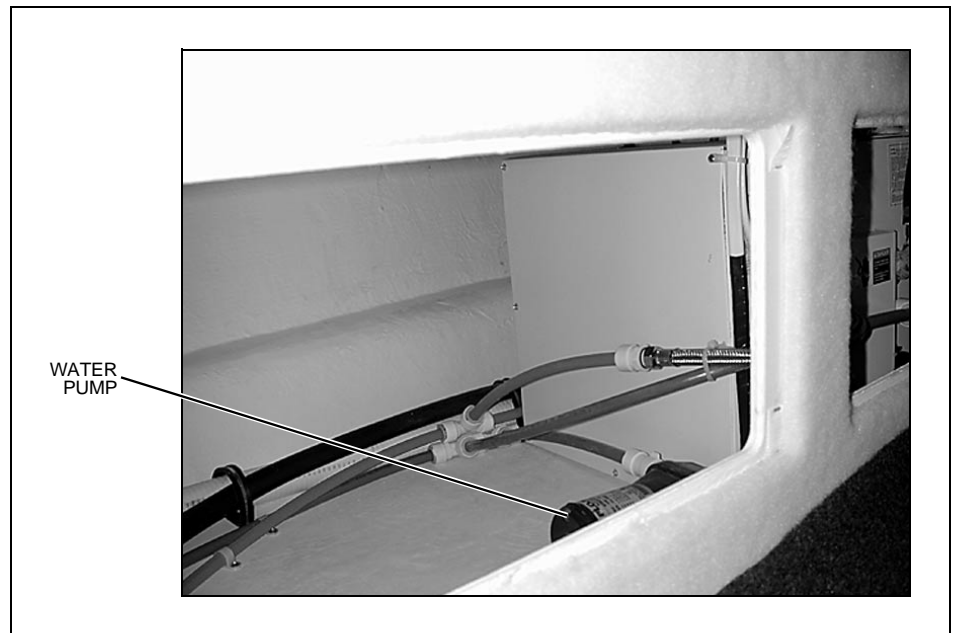

**Water Pump Switch:**

On the DC panel in the AC/DC cabinet

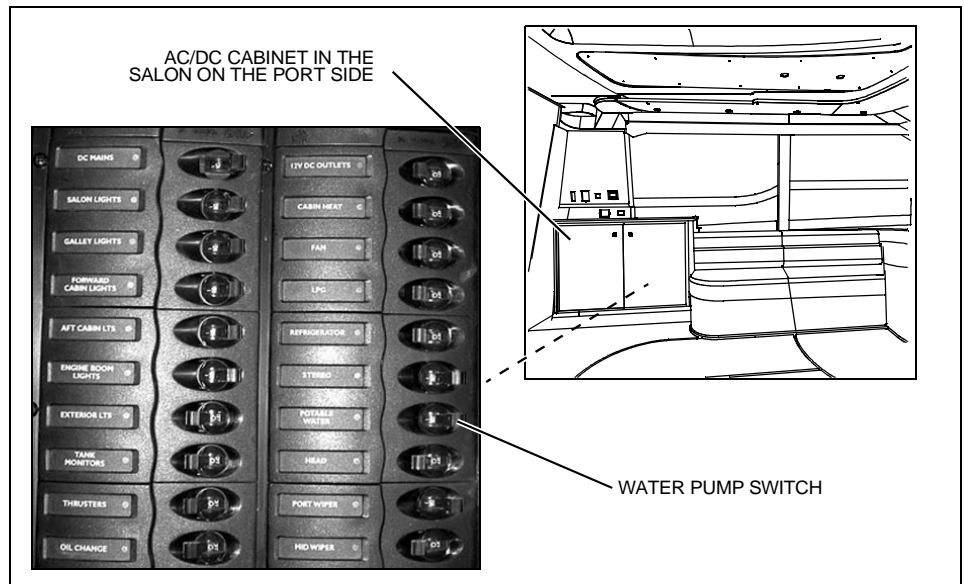

## Chapter 3: Propulsion & Related Systems

### Engine

Read and understand the engine operation and maintenance manuals *before* using or working on the engines.

#### Engine Cooling System

CAUTION!

***SYSTEM DAMAGE HAZARD!***

The engine cooling system's seacocks *must* be *Opened before* engines are started and during engine operation.

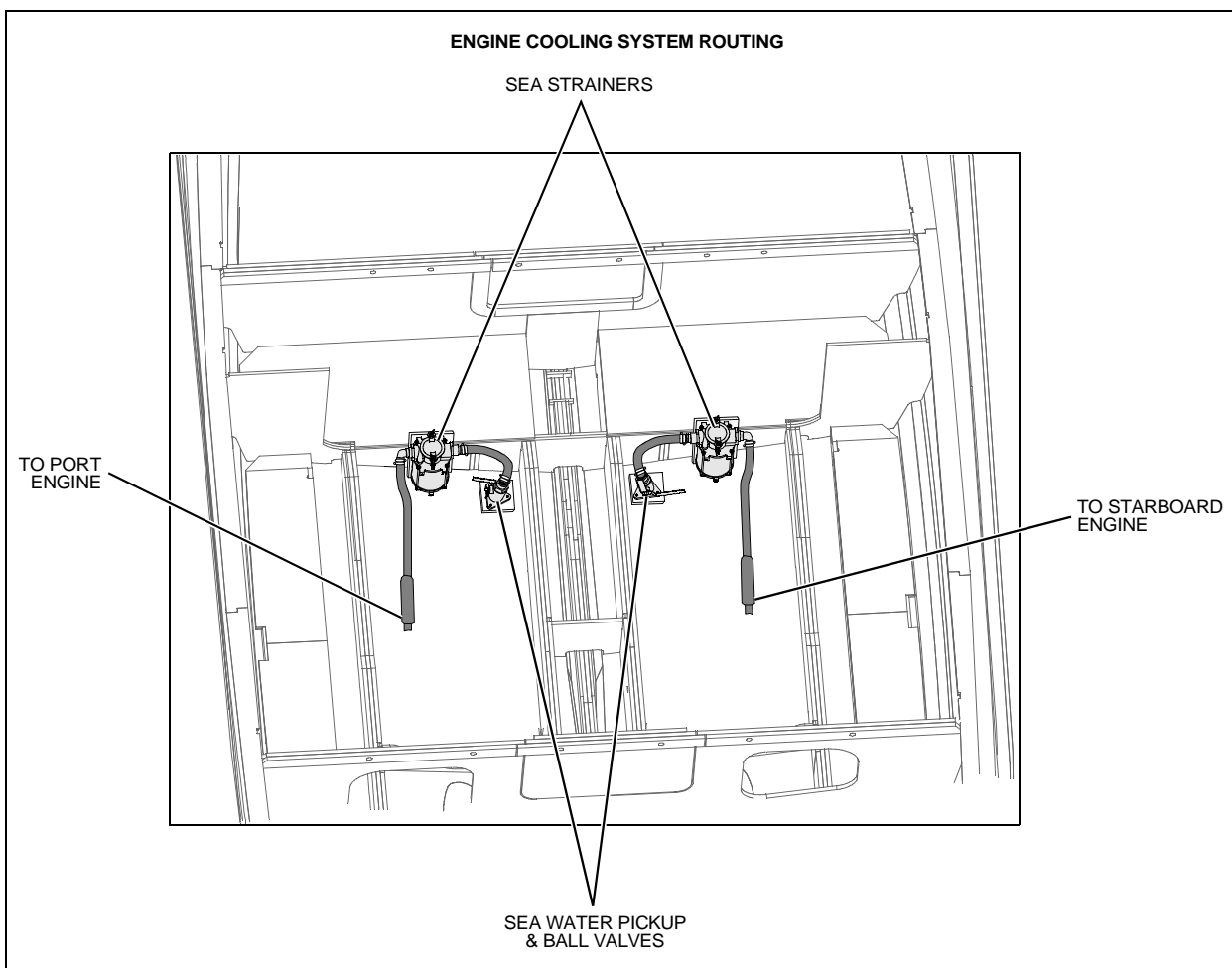

The engine cooling system circulates raw water around components and also uses a freshwater heat exchanger on the engine to reduce engine temperature.

- Make sure both engine seawater intake valves (seacocks) are *Open before* starting the engines and keep the seacocks *Open* while the engines are running.
- The cooling system's seawater strainers should be checked for leaks and debris *every time* you use your yacht. For instructions on how to clean the seawater strainers, see the *Seawater Systems* section of this *Owner's Manual*.

## Exhaust System

⚠ **DANGER!**

CARBON MONOXIDE POISONING HAZARD!



**DANGER**  
CARBON MONOXIDE

Leaking engine and/or generator exhaust is a source of dangerous carbon monoxide gas (CO). Check *all* exhaust systems *before* each trip.

- Look for leaks in the exhaust systems of the propulsion engines and the generator.
- Look for discoloration, water leaks, carbon or stains around *all* joints.
- Make sure *all* of the exhaust clamps are in place and secured.
- Make sure the ventilation systems work and are *not* obstructed or restricted.
- To reduce the chance of CO entering the living spaces, fill any gaps around engine room plumbing, cableways, exhaust systems, doors, hatches, and access panels.

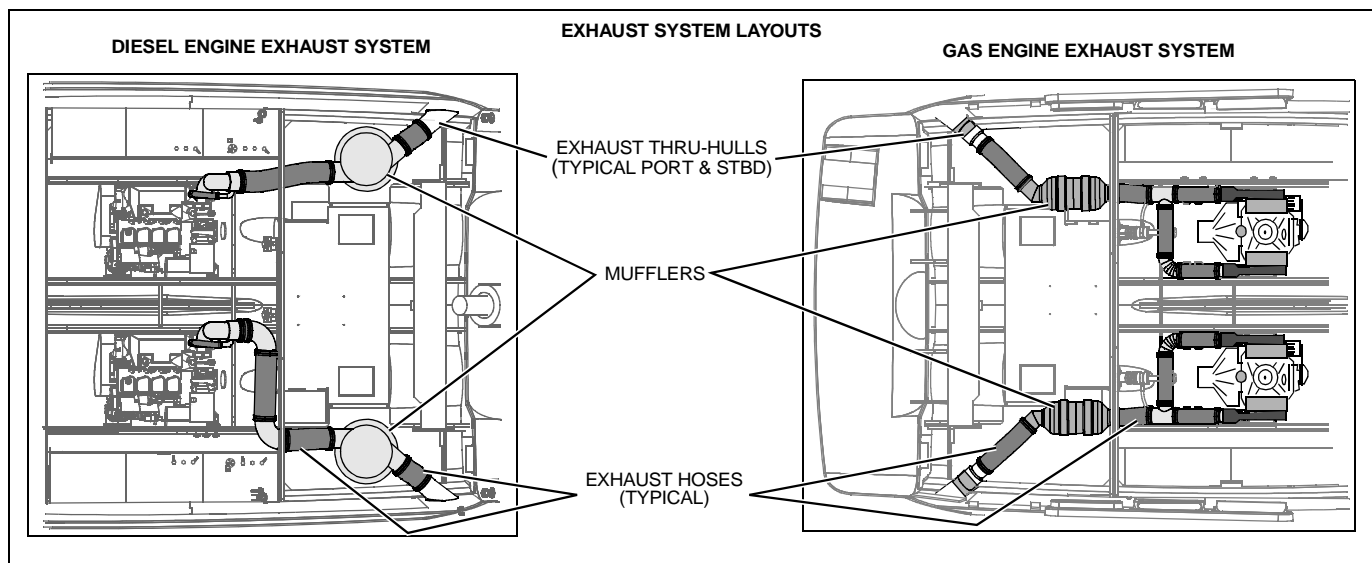

- The exhaust system is designed to keep seawater out of the engines in most sea conditions.
- However, *do not* anchor the stern to sea or shut the engines *Off* if high seas might flood the exhaust system.
- *Always* consider the sea conditions *before* anchoring or shutting *Off* the engines.



## Engine Room Ventilation System

**⚠ WARNING!**



**FIRE/EXPLOSION HAZARD**

- Use of the blower system is *NOT A GUARANTEE* that explosive fumes have been removed.
- If you smell fuel, *DO NOT* start the engines or generator and *DO NOT* turn *On* any electrical devices.
- If you smell fuel and the engines and/or generator are already running, shut *Off* the engines and/or generator and turn *Off all* electrical devices. Investigate *immediately*.
- *DO NOT* obstruct or modify the ventilation system.

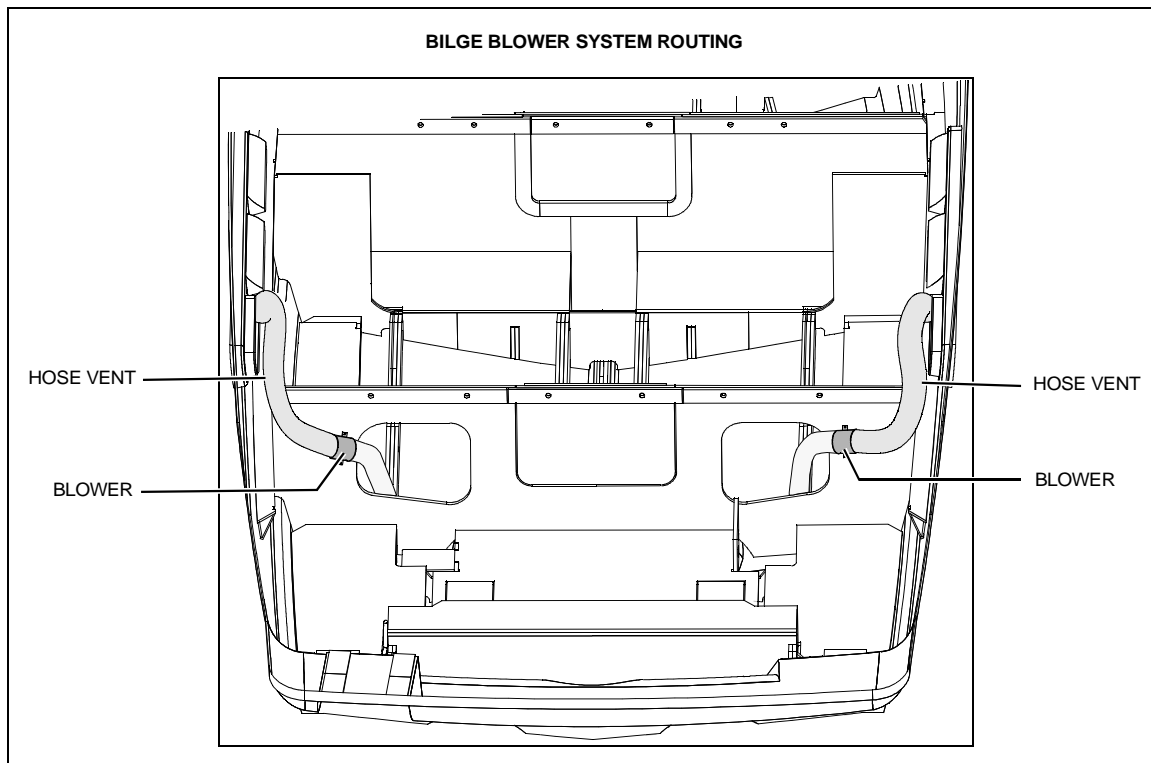

- The bilge blowers remove explosive fumes from the engine room.
- Fresh air is drawn into the engine room through the deck vents.
- The bilge blower switch is located on the switch panel at the helm.

To make sure the engine room is properly ventilated:

- *Always* run the bilge blowers for at least four minutes *before* starting the engines or the generator (if equipped).
- Continue to run the blowers until your yacht has reached cruising speed.
- *Always* run the blowers when operating the yacht below cruising speed.

## Fuel System

Carefully read this section, and the fuel section of both the *Cruiser & Yacht Owner's Manual Supplement* and the engine operation manual, paying special attention to the subject of *fuel recommendations*.

**! WARNING!**



**FIRE, EXPLOSION AND OPEN FLAME HAZARD!**

- It is very important that the fuel system be inspected thoroughly the first time it is filled and at each subsequent filling.
- The fueling instructions in the *Cruiser & Yacht Owner's Manual Supplement* and the *fuel recommendations* in the engine operation manual *must* be followed.

**! CAUTION!**

- Air in the diesel supply system can stop an engine or severely restrict performance. If you suspect air in the fuel lines, refer to your engine operation manual for detailed instructions on how to *bleed* the system.

**! CAUTION**

**Avoid the storage or handling of gear near the fuel lines, fittings and tank.**

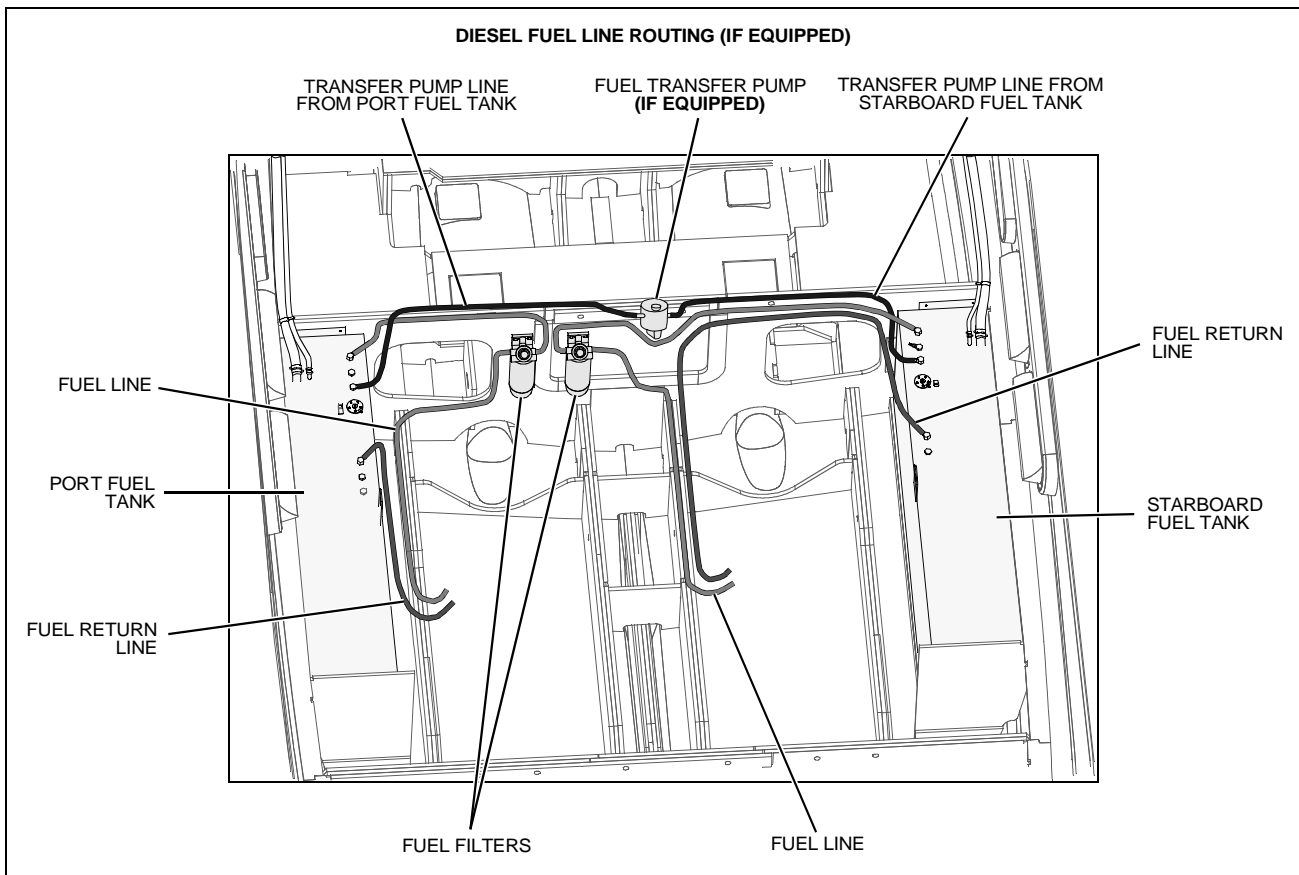

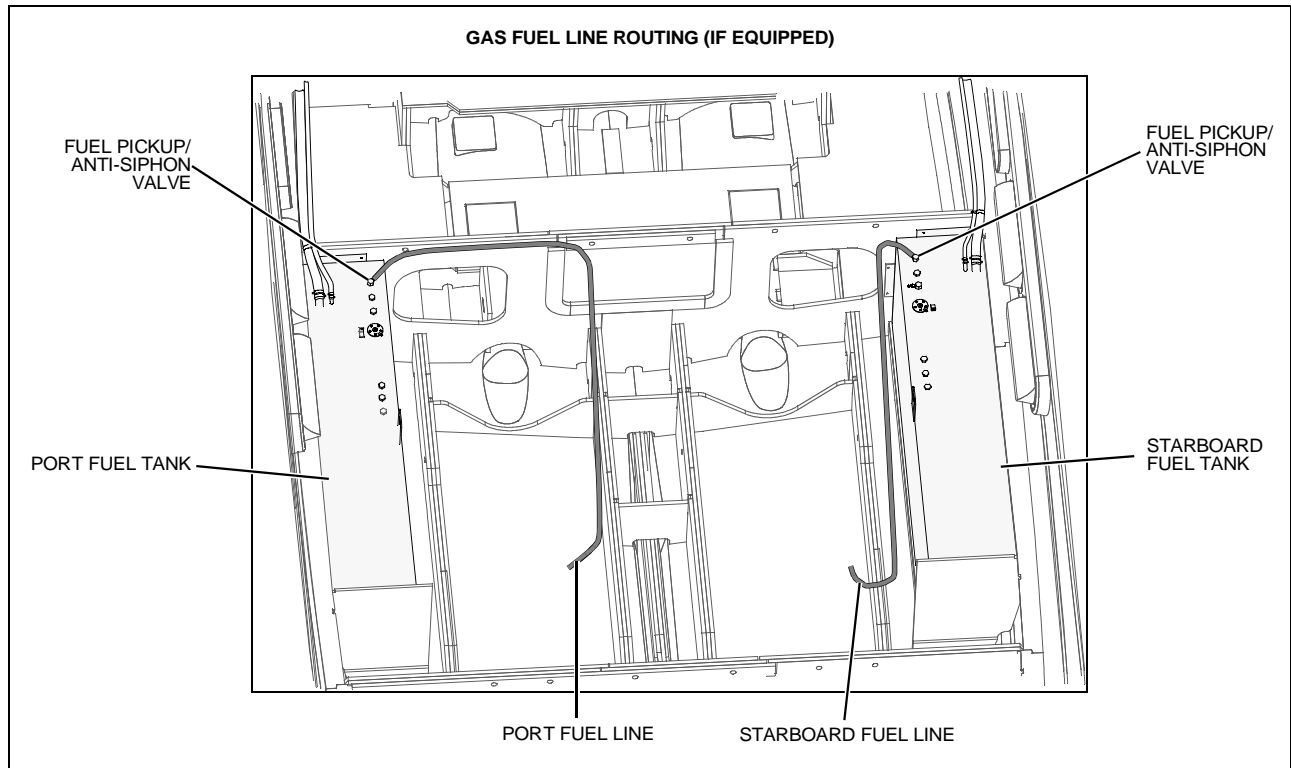

**Fuel Fills & Vents**

- The fuel fill fittings are marked “Diesel” or “Gas”.
- If you experience difficulty filling the fuel tank, check to see if the fuel fill hose is kinked or collapsed. If there are no visible signs of a problem, contact your local dealer.

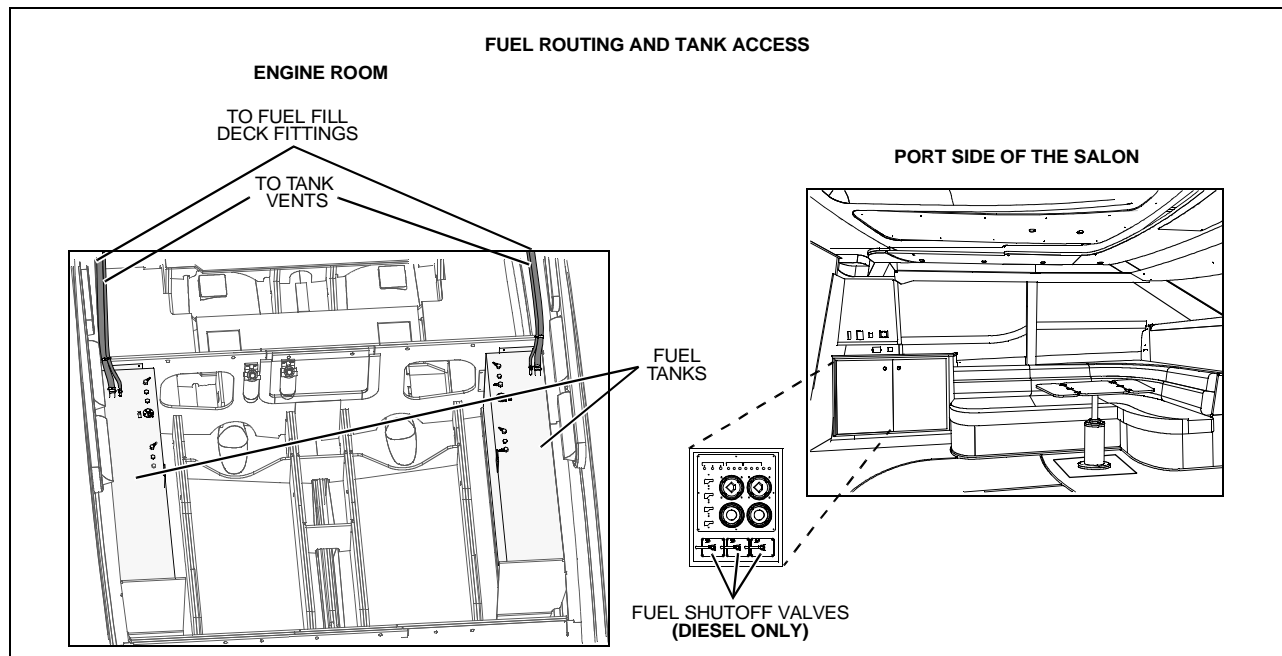

### **Fuel Transfer Pump (If Equipped)**

 <b>CAUTION!</b>
<b>ENVIRONMENTAL HAZARD!</b> <b>NEVER transfer fuel into a full (or nearly full) fuel tank. Fuel transferred into a full tank may spill overboard through the tank venting system.</b>

Your yacht may feature a fuel transfer pump which pumps fuel from one tank to another. The fuel transfer pump switch is located at the upper helm station.

### **Fuel Filters**

- The fuel pickup tube (located inside the fuel tank) is equipped with a fine mesh screen filter (gas only).
- In addition, when supplied by the engine manufacturer, a fuel filter is installed on the engine.
- Periodically replace the fuel filters to make sure they remain clean and free of debris.
- Consult with your selling dealer or local marina concerning fuel additives that help to prevent fungus or other buildup in your fuel tank.

### **Anti-siphon Valve (If Equipped)**

<b>NOTICE</b>
<ul style="list-style-type: none"> <li>• <b>If an engine running problem is diagnosed as fuel starvation, check the anti-siphon valve. If the valve is stuck or clogged, change or replace it while the engine is shut down.</b></li> <li>• <b>NEVER run the engine with the anti-siphon valve removed, except in an emergency.</b></li> </ul>

- Gas fuel systems are equipped with anti-siphon valves.
- The valves are located at the point where the fuel feed line attaches to the fuel tank.
- The valve is spring loaded and is *Opened* by fuel pump vacuum.
- This valve will prevent fuel from siphoning from the tank in the event of a fuel line rupture.

## Oil Change System (If Equipped)

Your yacht may feature an oil change pump to simplify draining and filling engine and generator oil. See the oil change system instructions for information on the use of this system.

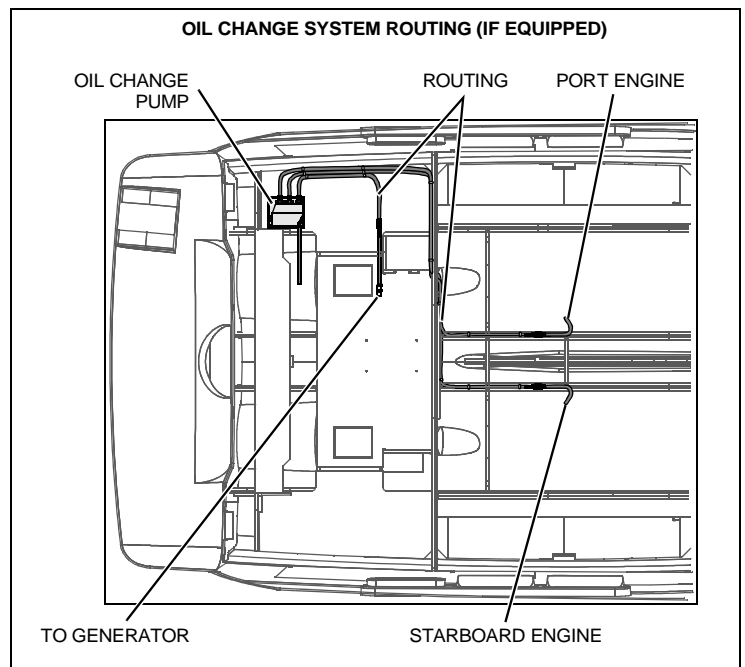

## Fire Suppression System (If Equipped)

**Before** using your boat for the first time, read and understand the fire suppression system's instruction and maintenance manual and follow **all** warnings.

Observe the following:

- The system **will** go off automatically whenever direct heat from a fire is detected in the engine compartment.
- The system can be set off manually by pulling the T-handle (labeled "FIRE") at the helm.
- The system can only be set off once during a fire. After the system is discharged it **must** be refilled and refurbished **before** it can be used again.

## Shaft-Transmission Alignment



### CAUTION!

#### SYSTEM DAMAGE HAZARD!

- If you suspect a shaft-transmission misalignment, have a qualified mechanic perform an alignment inspection as soon as possible.
- Continued use may lead to premature engine, transmission, shaft, shaft seal and/or hull damage!

Alignment between the engine transmission output shaft and the propeller is very critical. The alignment has been performed at the factory and was rechecked by the dealer after the yacht had been in the water for 48 hours.

- An alignment inspection should be performed by a marine mechanic as part of the routine maintenance program after the initial 30 hours of operation, then every 60 hours and whenever unusual noise or vibration is noticed.
- Shaft-transmission alignment should be performed by a marine mechanic since it requires moving the engine and prop shaft.
- To insure proper alignment after a haulout or dry storage, wait 48 hours after launching *before* final alignment adjustments by a marine mechanic are made.

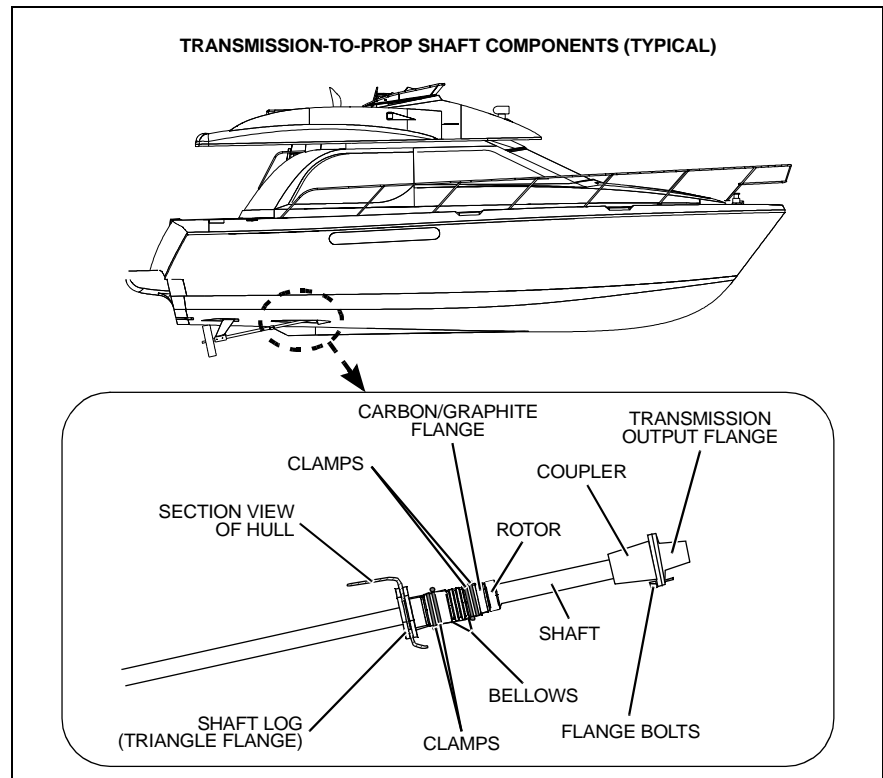

### Shaft Log Packless Sealing System

The shaft log packless sealing system's shaft seal is a maintenance-free, watertight seal that does *not* require packing or adjustments.

## Chapter 4: Controls & Gauges

### Steering

- This yacht features a power assisted rack-and-pinion steering system.
- Check the fluid level in the power steering reservoir *every time* you use your yacht.
- Yacht steering is *not* self-centering.

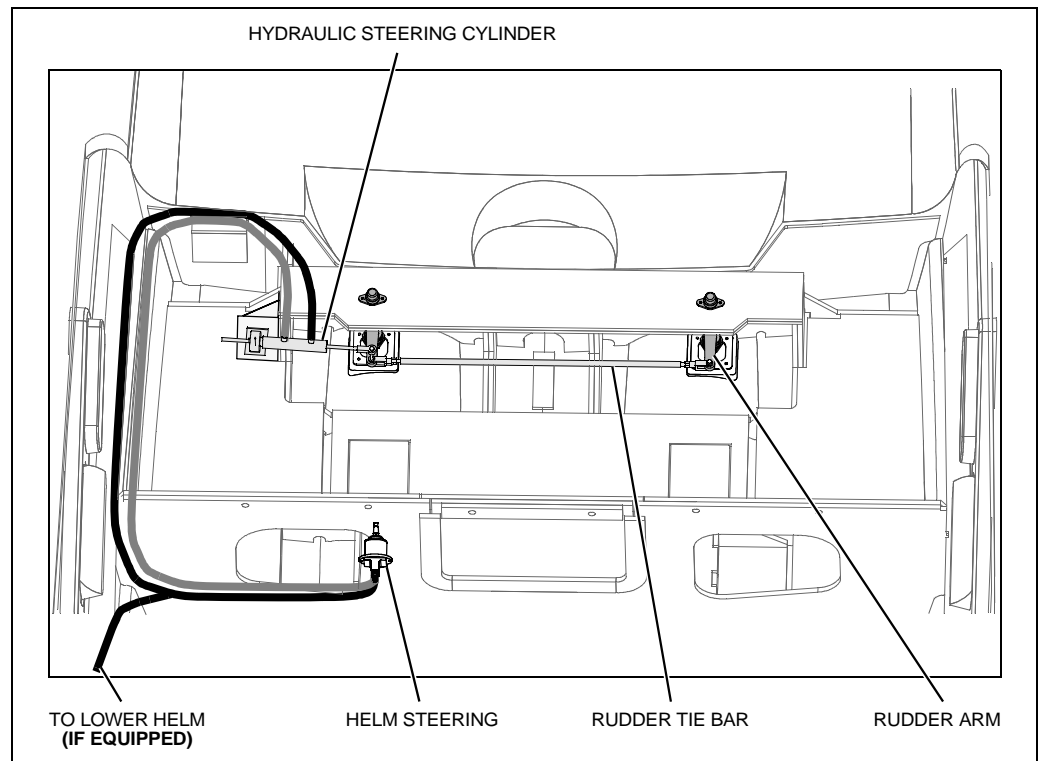

### Rudder Stuffing Gland

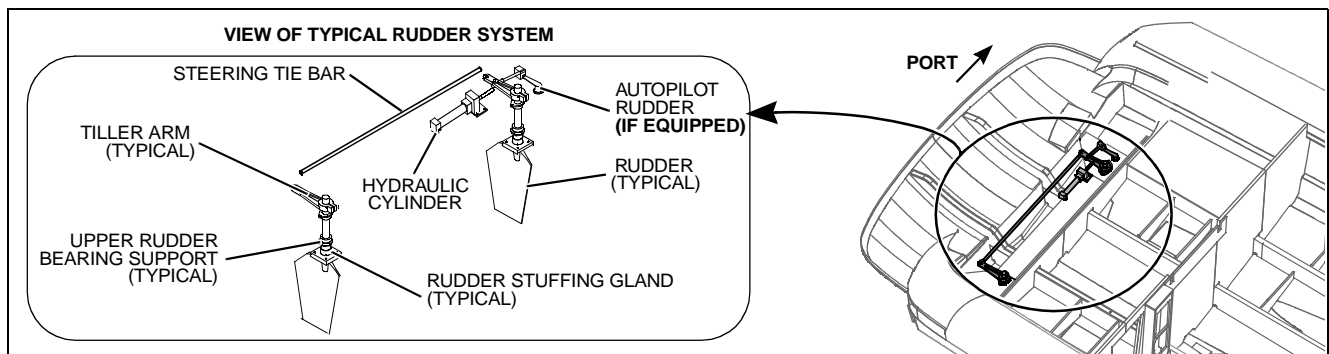

The rudder stuffing gland is part of the assembly where the rudders emerge from the bottom of the yacht. The shaft stuffing gland should *not* leak any water. If a leak develops, it can usually be stopped by tightening the packing gland nuts *slightly*. **Do not** over tighten the packing gland nuts. If stuffing gland leakage becomes excessive, packing replacement can be performed as follows:

1. Remove the yacht from the water.
2. Loosen the packing gland nuts and back the packing gland from the sleeve.
3. Remove the old packing.
4. Wrap new packing around the shaft.
5. Cut the rings with a razor blade at an angle approximately 30 degrees to the long axis of the shaft.
6. Stagger the ends of each ring around the shaft and insure that the rings are at the bottom in the sleeve.
7. Tighten the packing gland nuts until resistance is felt.

## Autopilot (If Equipped)



### WARNING!

- *Never* leave the helm while the autopilot system is *On*!
- A qualified operator *must* monitor the autopilot system at *all* times and keep lookout for other marine traffic and other hazards.

### NOTICE

- The autopilot system is *only* an aid to navigation.
- It's accuracy can be affected by many factors, including equipment failure or defects, environmental conditions & improper handling or use.

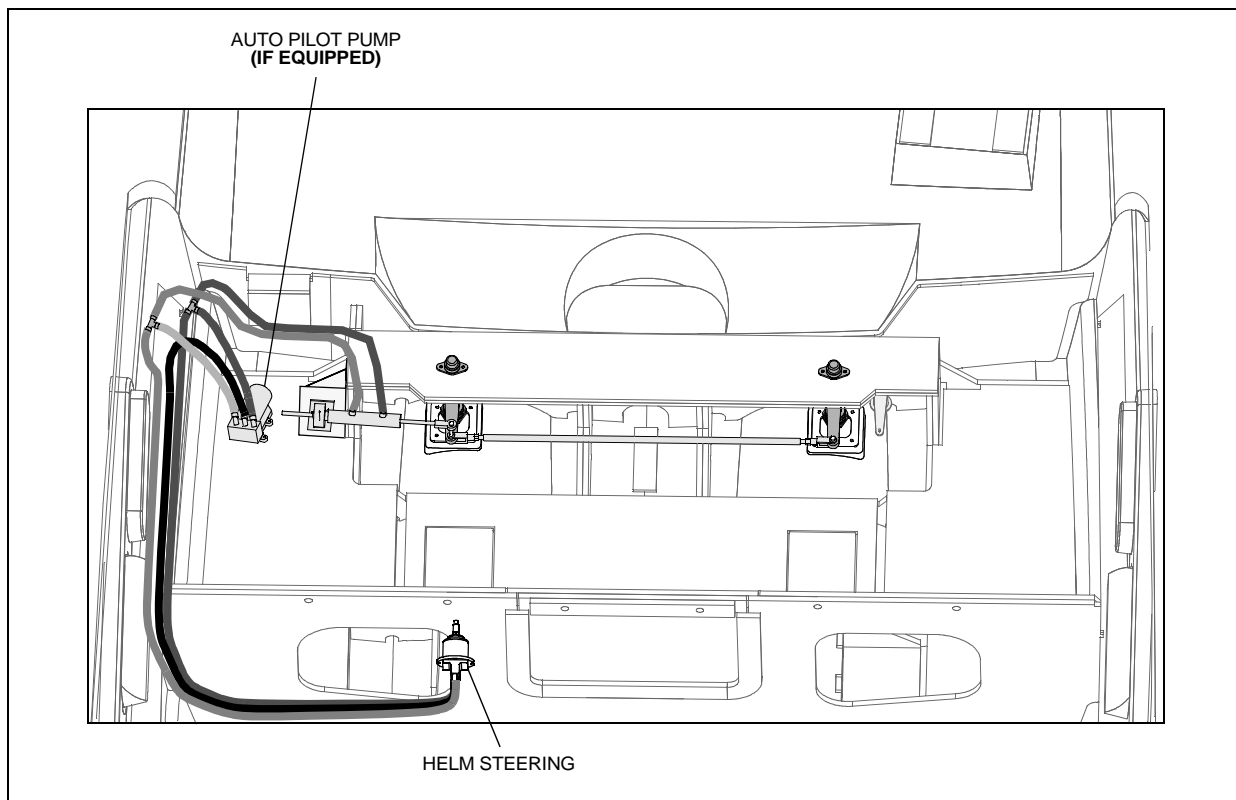

- *Before* using the autopilot system, read the autopilot instruction manual(s).
- The autopilot system can be turned *On* at the upper helm station.
- The autopilot *will* aid you in maintaining the chosen course of your yacht.



## Shift/Throttle Controls

**⚠ WARNING!**

***LOSS OF CONTROL HAZARD!***

**Improper maintenance of shift/throttle hardware may cause a sudden loss of control!**

Read **all** of the information about the shift/throttle controls in the shift/throttle controls' manual, the engine operation manual, and the *Cruiser & Yacht Owner's Manual Supplement*.

### **Engine Synchronization (If Equipped)**

Follow the instructions in the synchronization section of the shift/throttle controls' manual.

## Trim Tabs

**⚠ WARNING!**

***LOSS OF CONTROL HAZARD!***

**Improper use of trim tabs *will* cause loss of control!**

- ***Do not*** allow anyone unfamiliar with trim tabs to use them.
- ***Do not*** use trim tabs in a following sea as they ***will*** cause broaching or other unsafe handling characteristics.
- ***Do not*** use trim tabs to compensate for excessive unequal weight distribution.

- The trim tabs may be used to help keep your yacht level at cruising speeds.
- The trim tabs are controlled by two rocker switches at the helm.
- ***Before*** using the trim tabs read and understand the trim tab operation manual.

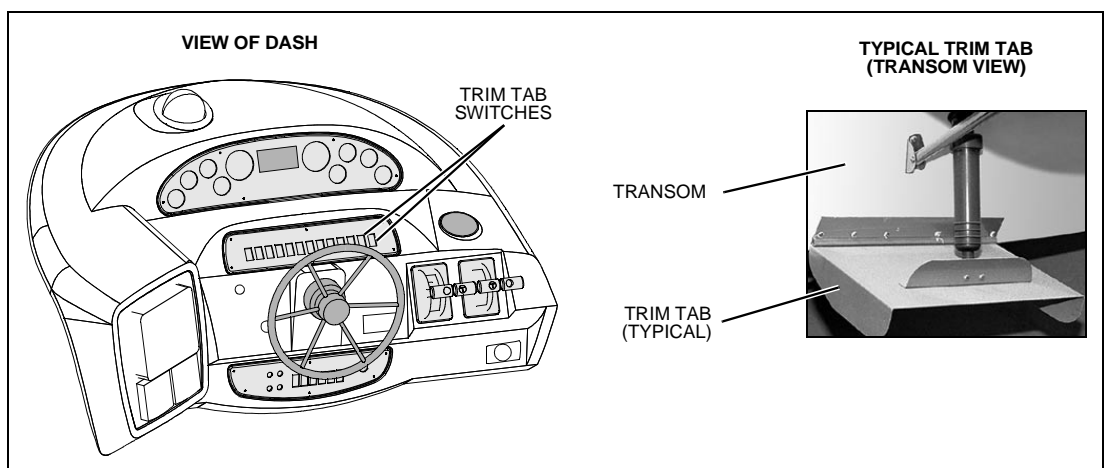

Observe the following:

- Once cruising speed is reached, the port or starboard trim switch may be used (one at a time) to level the yacht.
- Perform trim tab adjustment with several short touches to the switch rather than one long one.
- After each short touch allow several seconds for the hull to react.
- The trim tab hydraulic fluid reservoir is located in the engine compartment. The fluid level ***must*** be checked periodically (at least once a year) and refilled as necessary.

## Dual Thruster System (If Equipped)

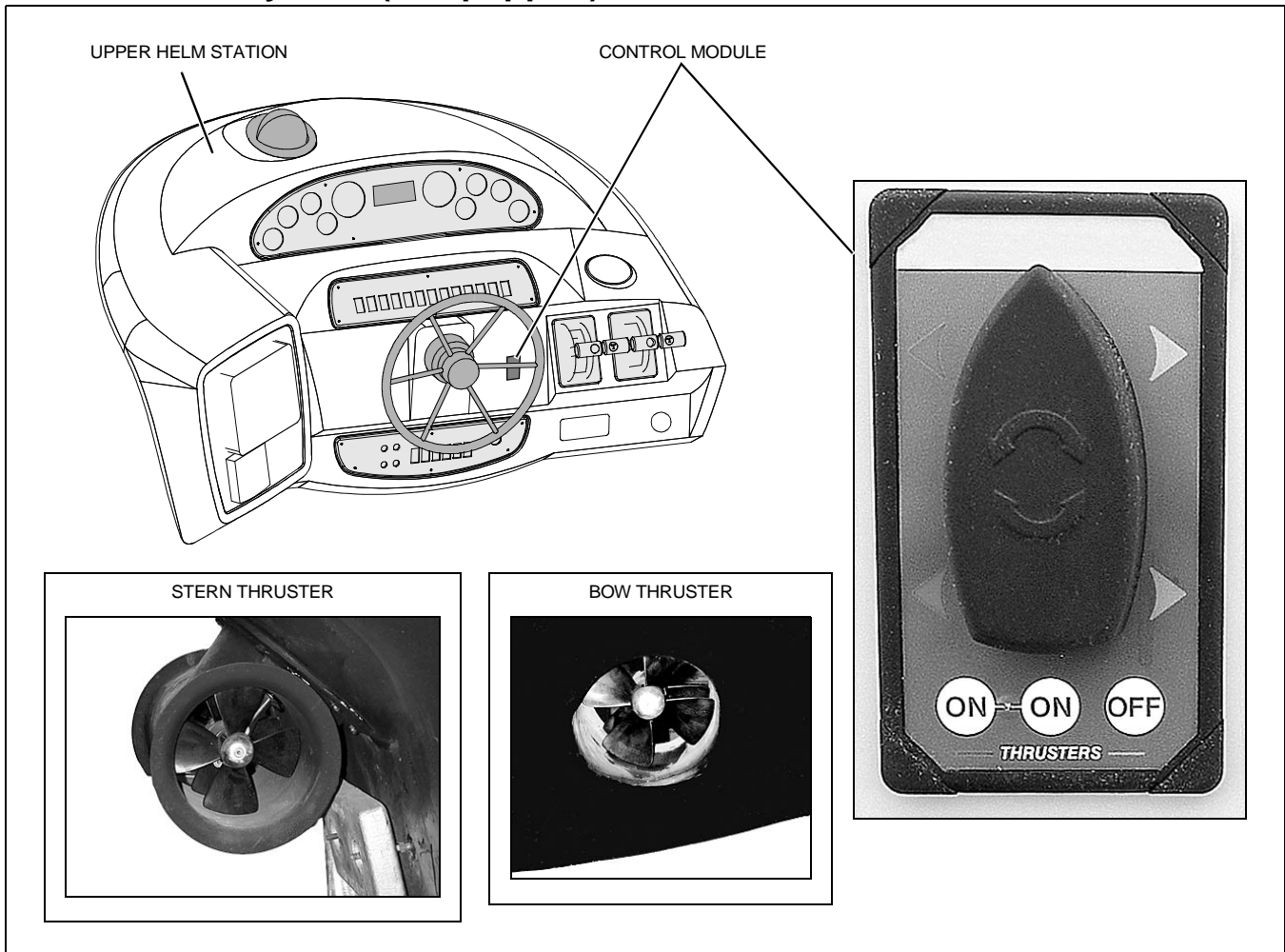

- Your yacht may feature bow and stern thrusters which can be controlled from either helm.
- The bow and stern thrusters allow you to maneuver your yacht in close quarters when docking.
- Read the bow and stern thruster's operation manual *before* using the bow and stern thrusters for the first time. Follow all user precautions carefully.

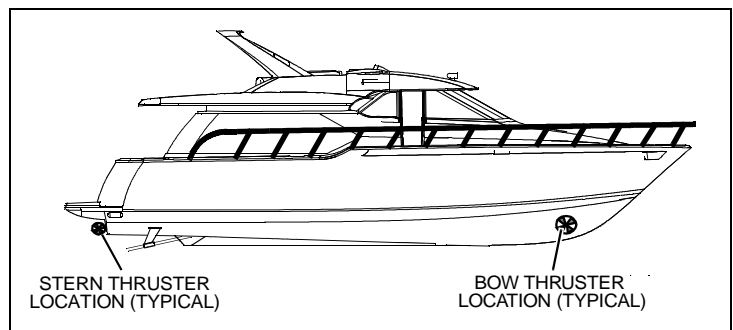

## Gauges

### *Cleaning Gauges*



### **CAUTION!**

#### ***PRODUCT or PROPERTY DAMAGE HAZARD!***

- Use only mild soap and water to clean the gauge lenses and bezels.
- Use of other cleaners, including common window cleaning solutions, may cause the lenses to crack.
- Lenses cracked in this manner *will not* be covered by our warranty.

### ***Gauge Fogging***

- Moisture may occasionally find its way into the gauges causing lens fogging.
- Turning on the gauge lights will help dry the lenses.
- Fogging *will not* harm the gauges.

### ***Radio Transmission Interference***

VHF or other radio transmissions may cause brief erratic readings on tachometers and/or synchronizers. This *will not* damage these gauges or affect their accuracy when *not* transmitting.

### ***Twin Engine Readings***

It is normal for tachometers and other gauges to have slightly different readings between engines.

### ***Fuel Gauge***

It is normal for the pointers on your fuel gauges to bounce as fuel sloshes back and forth in the fuel tanks.

### ***Synchronizer***

The synchronizer will help you run both engines at the same RPM (rotations per minute). Running synchronized engines will improve efficiency and reduce vibration.

- When both engines are running at the same RPM the pointer on the synchronizer will be in the center position.
- If one engine is running slower than the other the pointer will swing towards the slower engine.
- Center the pointer by adjusting the RPM on either engine.

## Chapter 5: Navigation & Communication Equipment

---

*Before* using these systems for the first time, read and understand the instruction manuals and observe the following:

### Compass

#### NOTICE

- Compass accuracy can be affected by many factors.
- Have a qualified technician calibrate your compass. Make sure the technician gives you a deviation card which shows the corrections to apply in navigational calculations.
- Keep a copy of the deviation card at each helm.

### Global Positioning System (GPS) (If Equipped)



#### WARNING!

The *GPS* system should *not* be relied upon as the only aid to navigation. A qualified operator *must* monitor the *GPS* system at *all* times and keep look-out for other marine traffic and possible collision situations.

#### NOTICE

The *GPS* system is only an aid to navigation. It's accuracy can be affected by many factors, including equipment failure or defects, environmental conditions & improper handling or use.

## Radar (If Equipped)

- The marine radar system gives you a complete and accurate 360° radar view of other vessels, buoys, and landfall surrounding your vessel.
- To turn this system **On**, the RADAR switch on the DC breaker panel must be switched **On**.

## VHF Radio (If Equipped)

- The VHF (Very High Frequency) radio can be used to access weather reports, summon assistance or contact other vessels as permitted by the FCC (Federal Communications Commission).
- Contact the FCC for licensing, rules and regulations concerning VHF radio usage.

## Depth Finder



### WARNING!

- **DO NOT** use the depth finder as a navigational aid to prevent collision, grounding, yacht damage or personal injury.
- When the yacht is moving, submerged objects will *not* be seen until they are already under the yacht.
- Bottom depths may change too quickly to allow time for the yacht to react.
- If you suspect shallow water or submerged objects, run the yacht at very slow speeds.

# Chapter 6: Plumbing

## Bilge Pumps

### NOTICE

Discharge of oil, oil waste or fuel into navigable waters is prohibited by law. Violators are subject to legal action by the local authorities.

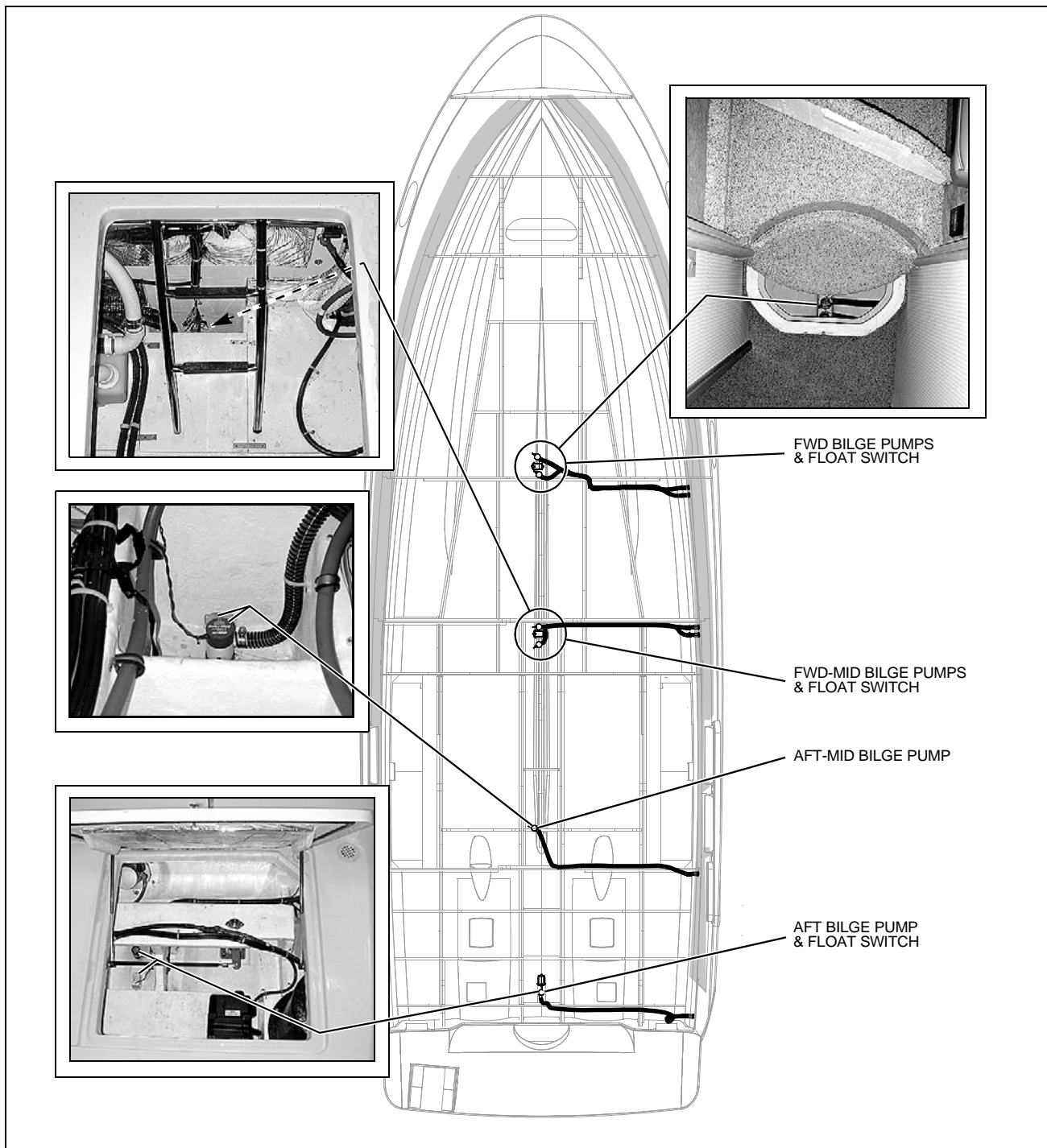

- Your yacht is equipped with six bilge pumps which are used to pump water out of the bilge.
- The bilge pumps are controlled by automatic float switches (autofloat switches) and/or switches at the helm.
- Since the bilge pumps are wired directly to the battery, they should work even when the yacht is shut down and left unattended.

### ***Bilge Pump Testing***

Bilge pumps are critical to the safety of your yacht. Check the bilge pumps often to make sure that they are working properly. Test each pump individually.

#### ***To test each bilge pump:***

1. Turn **On** the manual switches at the helm.
2. Make sure that water in the bilge is pumped overboard.

If there is water in the bilge and the pump motor is running but **not** pumping:

1. Inspect the discharge hose for a kink or collapsed area.
2. Check the bilge pump housing for clogging debris as follows:

#### ***To check for clogging debris in pumps:***

1. With your thumb and forefinger squeeze the holding tabs on each side of the power cartridge.
2. Lift out the power cartridge.
3. Check the pump and the housing and clear any debris.

#### ***Reinstall the power cartridge:***

1. Align the tabs and slots and press firmly until the tabs click into place.
2. Make sure that the power cartridge is locked into place.

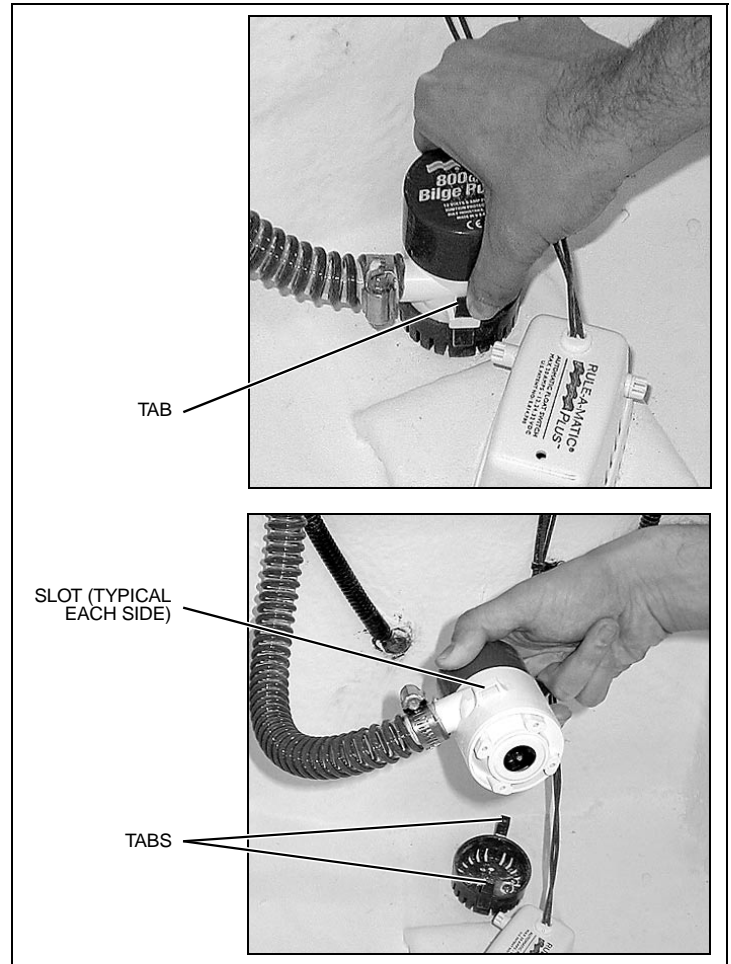

### Autofloat Switches

- The automatic bilge pumps use float (autofloat) switches to automatically turn **On** the pumps whenever water rises to a preset level in the bilge.
- The autofloat switches are normally mounted next to the bilge pumps they control.
- The autofloat switches should be tested often for proper operation as follows.

#### To test a float switch:

1. Turn **On** the float switch by twisting the white plastic knob 1/4 turn.
2. The bilge pump should turn **On**.
3. If twisting the knob does **not** turn the pump on, check the circuit breaker on the battery management panel.
4. If the circuit breaker is on, but the pump still does **not** work, it may indicate a bad switch or possibly a low battery.
5. Release the knob to lower the float and return the float switch to auto mode.

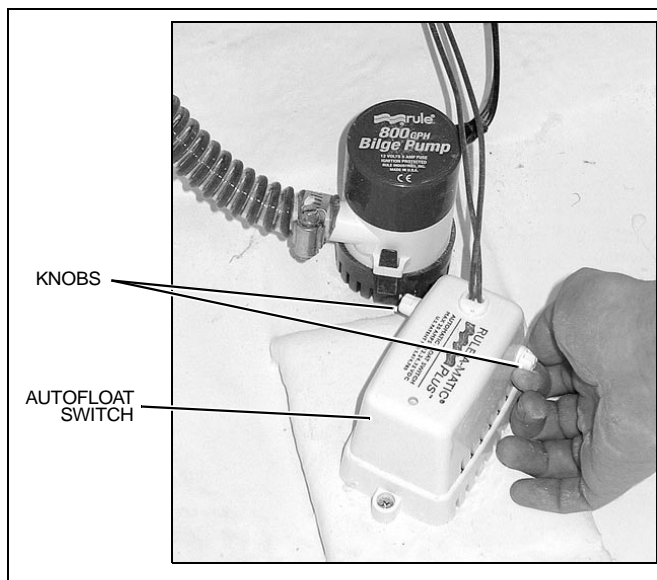

## CAUTION!

When the test is completed on each float switch, you **MUST** push the test button *all the way down* to the auto position to return the switch to auto mode!



## Seawater Systems

### Seacocks



### CAUTION!

#### SYSTEM DAMAGE HAZARD!

- *Before* using a seawater intake system, make sure that the system's seacock is in the *Open* position *before* the system is started and keep the seacock *Open* until the system is shut *Off*.
- *Close* the seacocks whenever the systems *will not* be used for long periods of time.

A seacock is a valve, controlled by a 90° lever, used to manage the intake of seawater through the hull and below the water line. Seacocks are typically used on your yacht in the following seawater intake systems:

- Engines
- Generator (if equipped)
- Air conditioning system (if equipped)

*Before* using any of these systems, make sure that the system's seacock is *Open* and remains *Open* until the system is shut *Off*.

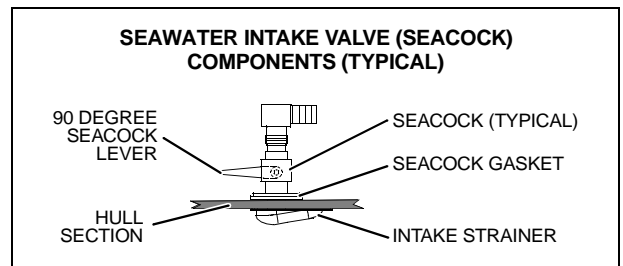

### Seawater Strainers

- Seawater strainers are used in water pickup systems to filter incoming seawater.
- A seawater strainer is located near each system's seacock.
- Check the strainers for leaks and/or debris *every time* you use your yacht.
- If debris is found, clean the seawater strainer as follows:



### CAUTION!

#### FLOODING HAZARD!

- The seacock that sends seawater to the strainer *must* be *Closed* *before* disassembling the seawater strainer to prevent the yacht from taking on water through the seawater strainer assembly.
- Keep the seacock *CLOSED* until the seawater strainer is completely reassembled.

#### SYSTEM DAMAGE HAZARD!

- *After reassembling* the seawater strainer, make sure that the seacock valve is *Open* *before* using the component/system.

1. Make sure the component/system (generator, air conditioning system, etc.) that the strainer is connected to is turned *Off*.
2. *Close* the seacock that sends seawater to the strainer you are about to clean. The seacock *must* remain *Closed* until the strainer is completely reassembled.
3. Take apart the seawater strainer.
4. Remove the debris.
5. Flush the strainer with water.
6. Reassemble the seawater strainer.
7. *Open* the seacock and check for leaks around the strainer. If no leaks are found, you may use the component or system.

## Raw Water Washdown (If Equipped)



### CAUTION!

#### **FLOODING & SWAMPING HAZARD!**

**NEVER** leave the boat unattended while using the "raw water" feature. Any leak or break in the system may allow large amounts of water to accumulate in the bilge that could cause swamping of the batteries and engines or sinking of the boat.

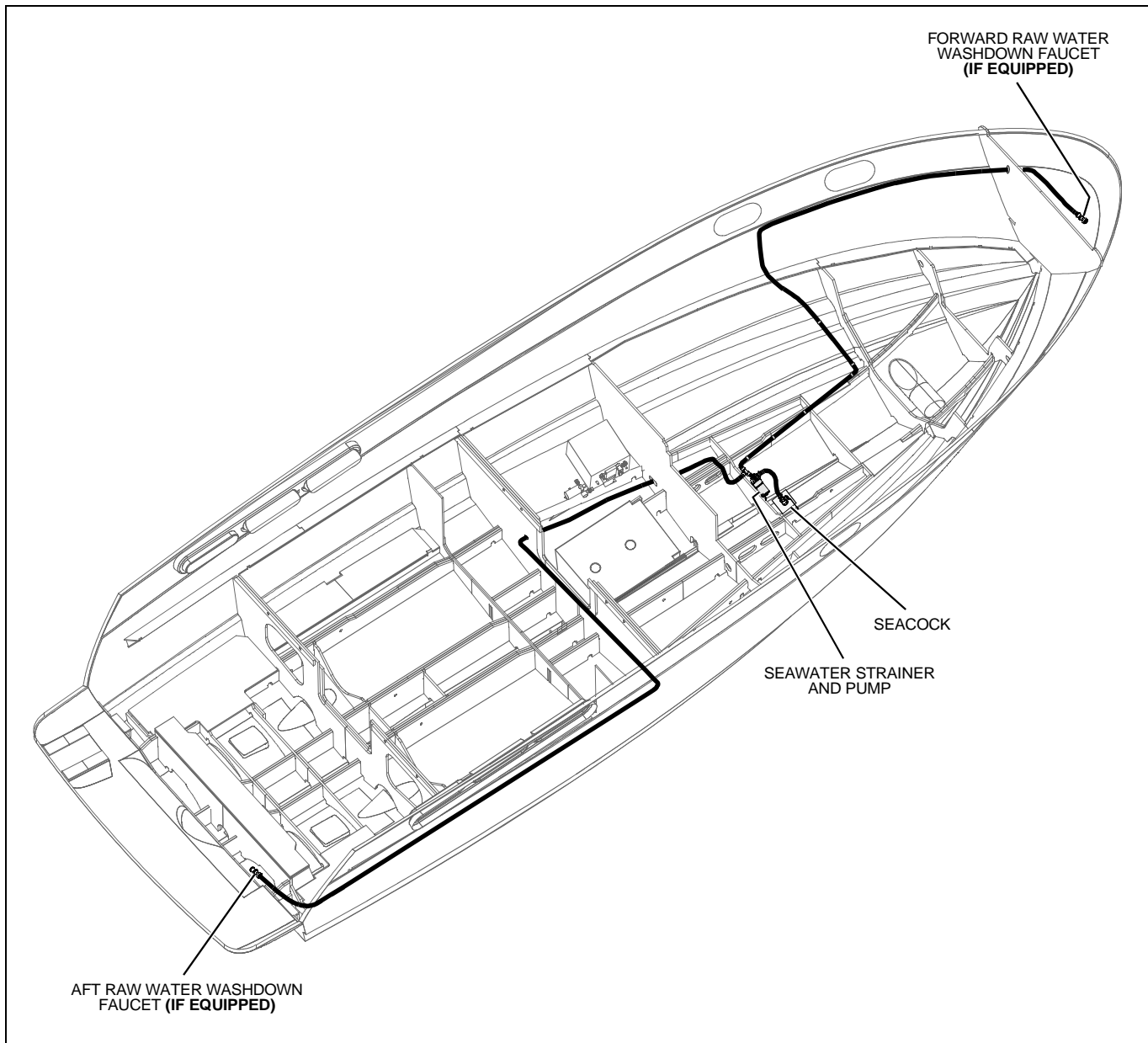

- The outlet for the raw water (seawater) washdown system is located on starboard side of the forward deck.
- Always make sure the seacock is **Open before** turning the raw water washdown system **On**.
- The seacock is accessed through the v-berth floor cutouts.

## Freshwater System

### ⚠ WARNING!

- Only use safe drinking (potable) water in your yacht's freshwater system.
- Only use a sanitary drinking water hose to fill the water tank or connect to city water.
- *Never* use a common garden hose for drinking water.

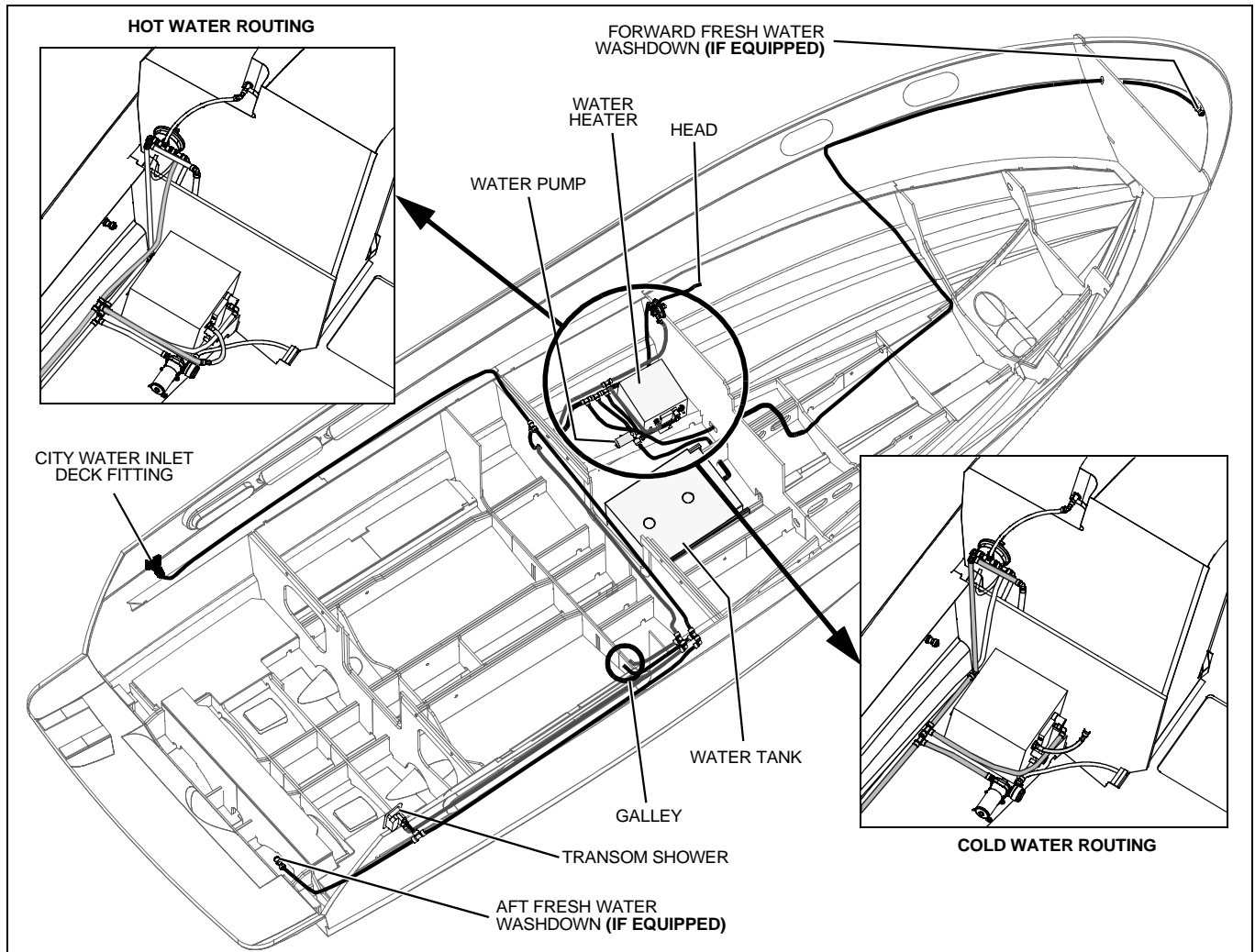

- Read the *Freshwater system* section in the *Cruiser & Yacht Owner's Manual Supplement*.
- Your yacht features a pressure type (demand) freshwater (potable) system.
- This system can be pressurized by turning **On** the water pump.
- See the *Component Location* section of this *Owner's Manual* for the location of the water pump switch.
- Since the water pump requires DC power, the battery switch **must** be in the **On** position for the pump to work.

Note the following about the freshwater system:

- Turn **Off** the water pump when the yacht is **not** in use or the water tank is empty.
- Inspect and clean the water filter often (located on the water pump).
- When your yacht is to be left unattended for long periods of time, pump the water tank dry to prevent stored water from becoming stagnant and distasteful.
- If the freshwater system needs disinfecting, ask your dealer about treatments available for your yacht's system.

## Freshwater System Winterization



### CAUTION!

#### WATER SYSTEM DAMAGE HAZARD!

Never blow compressed air through the water system when *all* of the faucets are *Closed*.

1. Turn **On** the water system switch.
2. **Open all** of the faucets and showers and let the water system drain completely.
3. Turn **Off** the water system switch.

Any remaining water **must** be removed from the water lines. There are two ways to remove the remaining water from the lines:

- Compressed Air
- Gravity Draining

### Compressed Air

You **must** have an air compressor, air hose and air nozzle.

1. Remove the water line from the outlet side of the water pump (opposite side from filter).
2. **Open** the faucet that is furthest away from the water pump.
3. Place the air nozzle against the end of the just removed water line and blow air through the system.
4. When water stops coming out of the **Open** faucet, stop the air and **Close** the faucet.
5. One at a time, repeat this process on **all** faucets and showers.

### Gravity Draining

1. **Open all** faucets and showers.
2. Remove the drain plug from the tee fitting on the freshwater tank.
3. When the water has stopped draining from the freshwater tank, replace the drain plug.

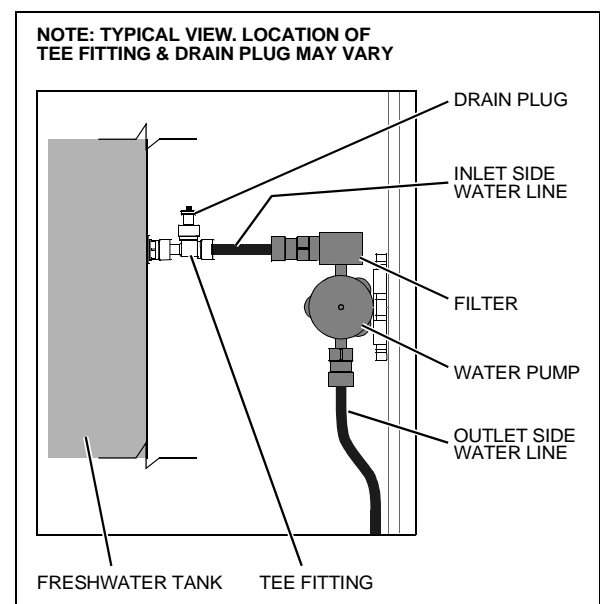

### Winterizing the Water Heater

1. Turn **Off** the water heater breaker.
  2. Disconnect the hose (A) attached to the pressure relief valve (B).
  3. If there is any water in this hose, drain it into the bilge or into a bucket.
  4. **Open** the pressure relief valve (B).
  5. **Open** the drain valve (C).
- Leave the pressure relief and drain valves **Open** until you fit out the boat after storage.



## Water Heater

**! WARNING!**

**! HOT HAZARD!**  
Water heated by the water heater can reach temperatures hot enough to scald the skin.

**! CAUTION!**

**WATER HEATER DAMAGE HAZARD!**

- **DO NOT** turn *On* the water heater electrical circuit on the AC panel until the water heater tank is **COMPLETELY** filled with water.
- Even momentary operation in a dry tank *will* damage the heating elements.
- Warranty replacements **WILL NOT** be made on elements damaged in this manner.
- The tank is full if water flows from the tap when the hot water is turned *On* in the galley.
- The water heater should be drained and the power turned *Off* when the possibility of freezing exists.

**NOTICE**

If your yacht is connected to shore power or generator power, but the water heater is *not* working:

- Make sure the water heater circuit breaker on the AC panel is switched *On*.

If the circuit breaker on the AC panel is *On*, but the water heater is still *not* working:

- Consult with your dealer about checking the "push to reset" circuit breaker located on the water heater.

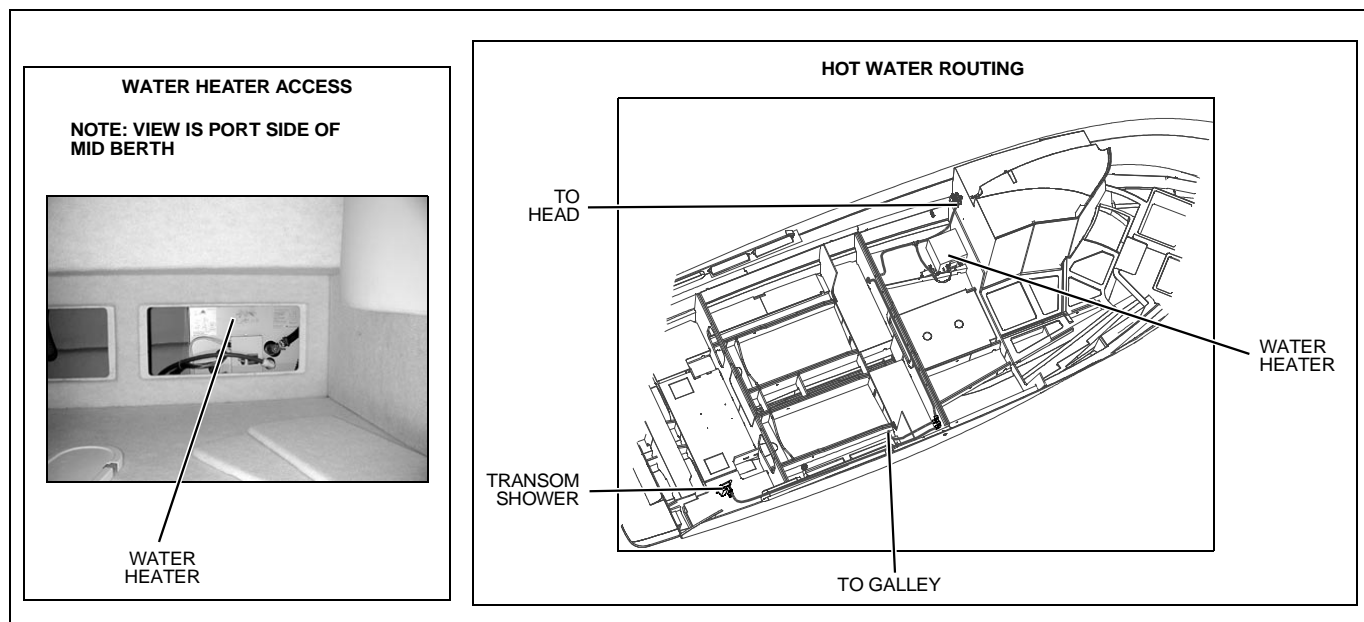

- Read the water heater instruction manual and heed the warnings above.
- The water heater is connected to the 120-volt, AC power system.
- Turn *On* the water heater breaker on the AC panel to heat the water.
- Refer to the Freshwater System Winterization section to winterize the water heater.

### Transom Shower

- Your yacht features a fresh-water transom shower.
- Read the manufacturer's instructions *before* using the transom shower for the first time.
- The water pump switch *must* be turned *On before* using the transom shower.

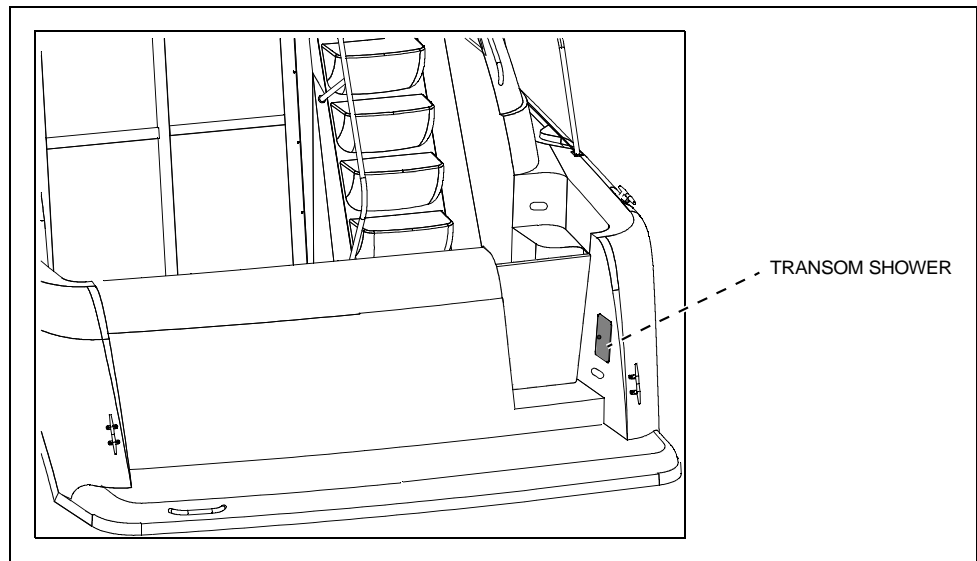

### City Water Inlet



## CAUTION!

### **FLOODING & SWAMPING HAZARD!**

**NEVER** leave the yacht unattended while using the "city water" feature. Any leak or break in the system may allow large amounts of water to accumulate in the bilge that could cause swamping of the batteries and engines or sinking of the yacht.

- Read the "City Water Hookup" portion of the *Freshwater System* section in the *Cruiser & Yacht Owner's Manual Supplement*.
- When the yacht is connected to a dockside water supply, the freshwater system is pressurized. You *do not* need to turn *On* the water pump's DC breaker, located on the DC panel.

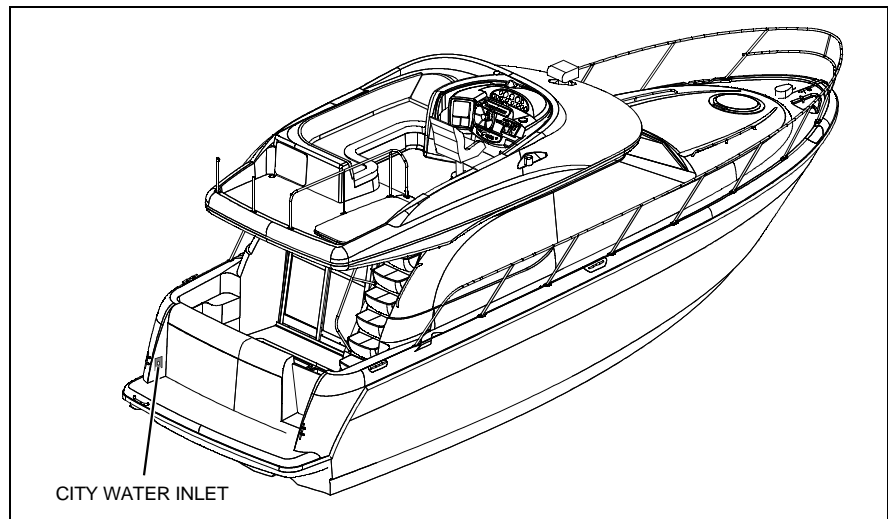

## Drain Systems

### Deck Drains

- Water on the deck is drained overboard through the deck drains.
- Keep the deck drains free of debris.

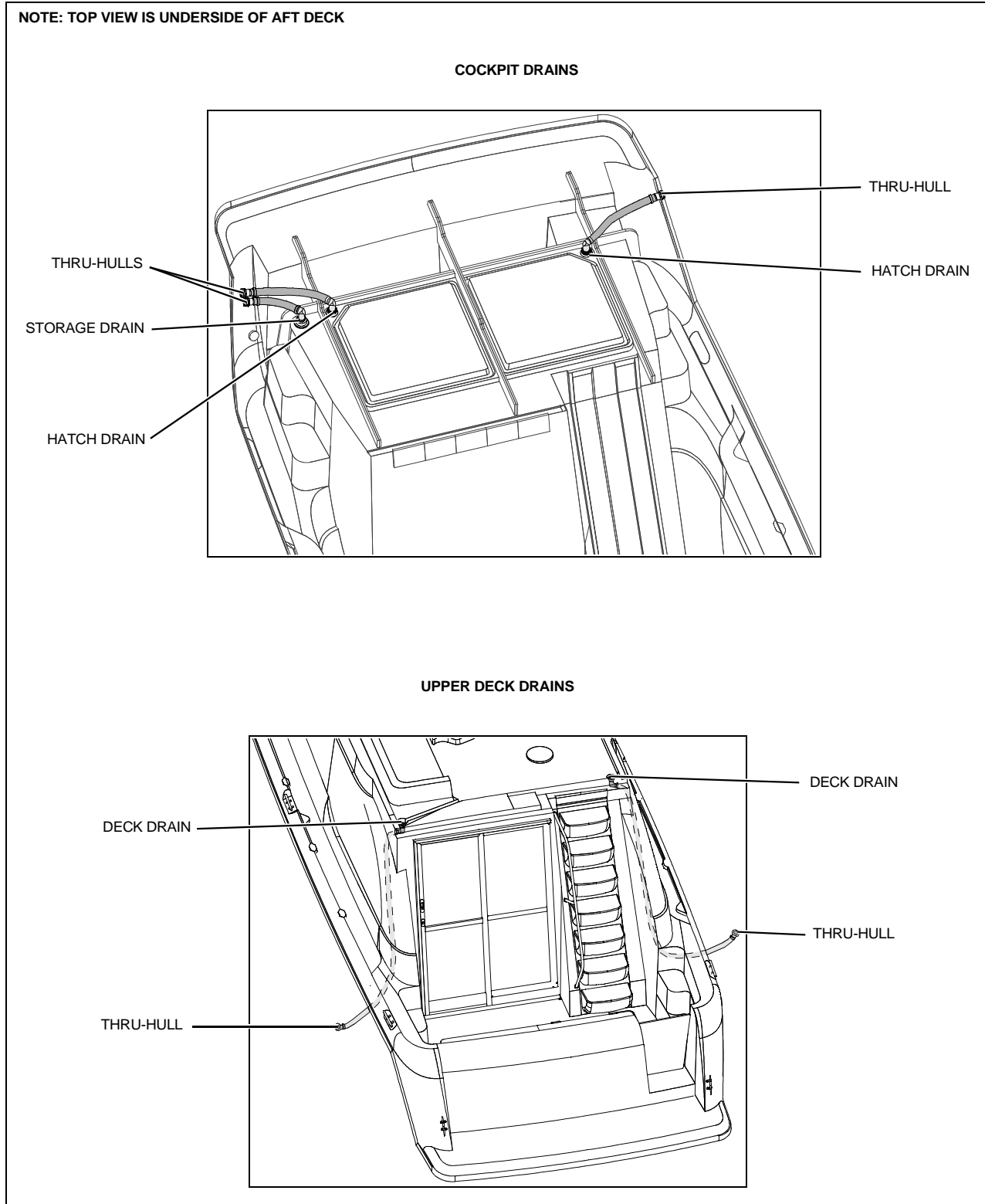

## Sink Drains

Gray water (water from the sinks) is gravity drained overboard.

## Shower Drain System

- The shower is drained into a sump box.
- A float switch automatically turns **On** the sump pump.
- The sump pump pumps the shower water overboard.

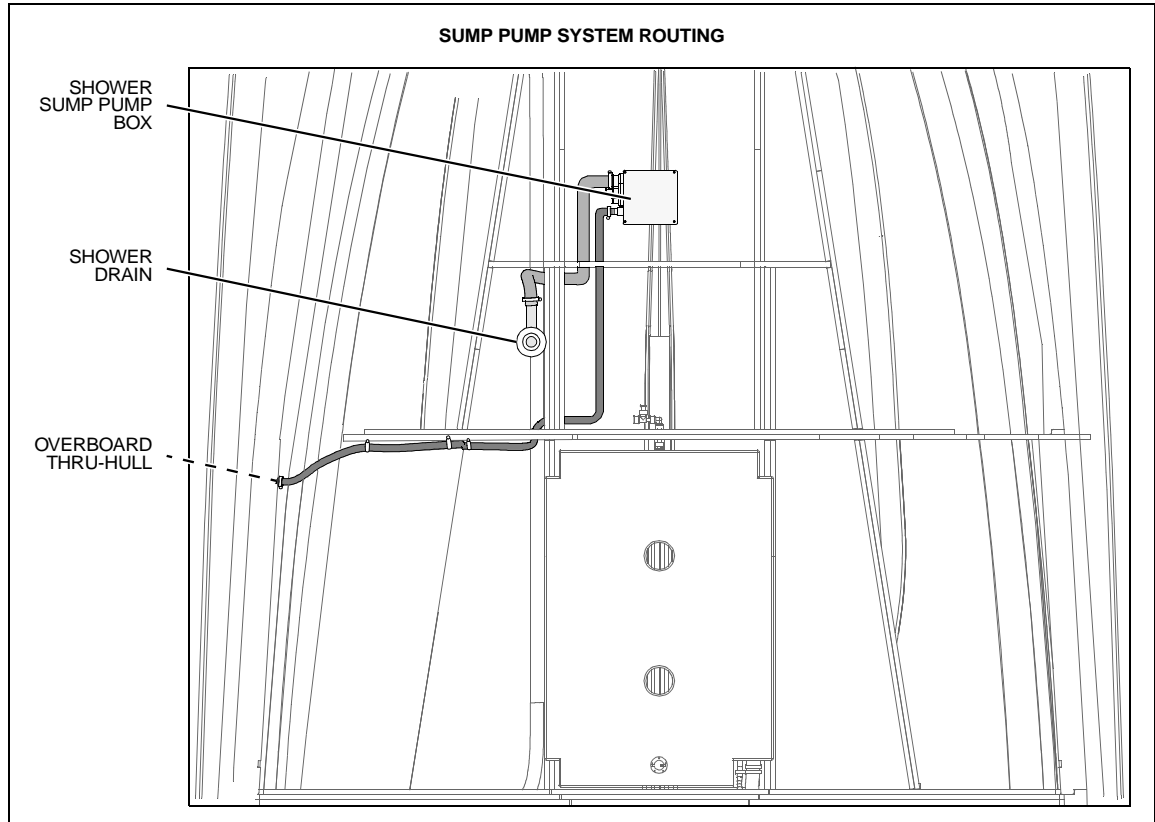

## Sump Box Cleaning

Periodically clean the sump box (A), filter, and pump as follows:

1. Remove the cover screws (B) and the cover (C).
2. Remove any debris from the box and the filter.
3. Clean the sump pump as outlined in the Bilge Pump section of this *Owner's Manual*.

## Sump System Winterization

Drain the sump pump system in the winter months when **not** in use.

1. Disconnect and drain **all** lines to the unit.
2. Remove the screws from the mounting feet (D) and drain the system.
3. Reinstall the screws in the mounting feet and reconnect the system.

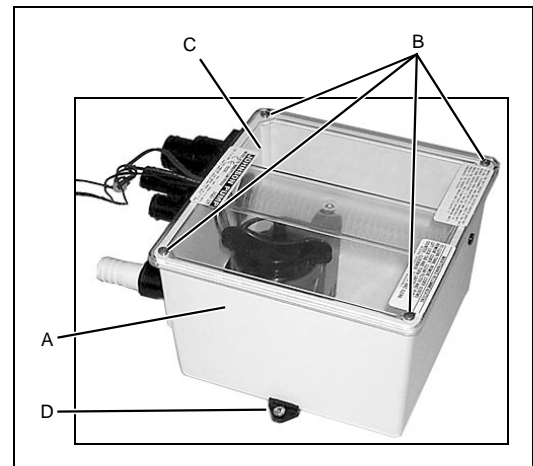



## Marine Head with Holding Tank

### NOTICE

Check with local authorities for regulations regarding the legal use of marine head systems.

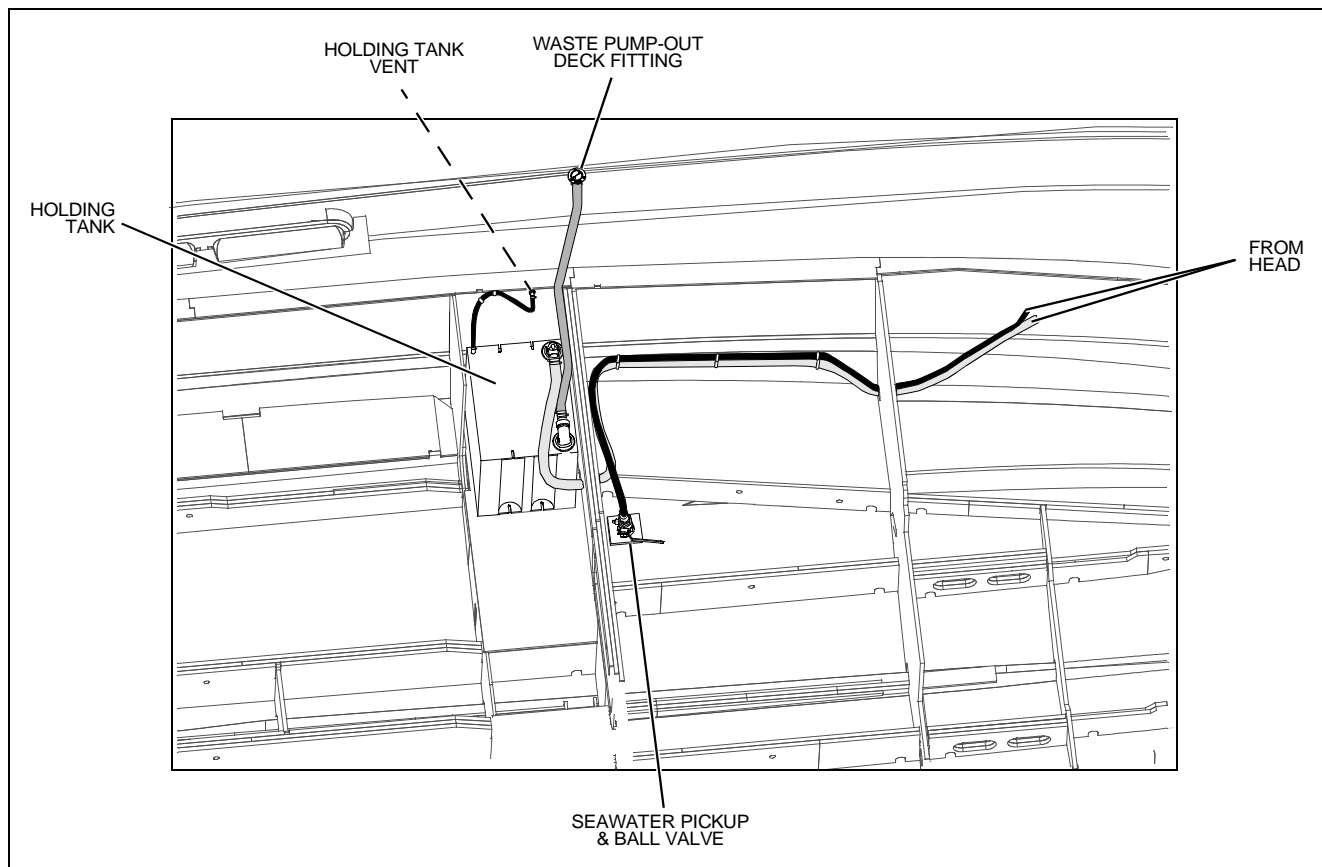

- Read the marine head operation and maintenance manual *before* using the marine head for the first time.
- The holding tank is plumbed to a waste fitting on the deck for dockside pump-out.
- Check the content level of the holding tank by looking at the side of the tank.
- Empty the holding tank at every opportunity.

### Winterizing The Marine Head

1. Shut *Off* the intake seacock, and pump the head until the bowl is dry.
  2. Remove the drain plug in the base and pump again to remove *all* of the water.
- *Do not* fill the bowl with anti-freeze.
  - *Close* the intake seacock while the yacht is underway or whenever the yacht is left moored in the water.

**Macerator (If Equipped)****NOTICE**

**Check with local authorities for regulations regarding the legal use of marine head systems.**

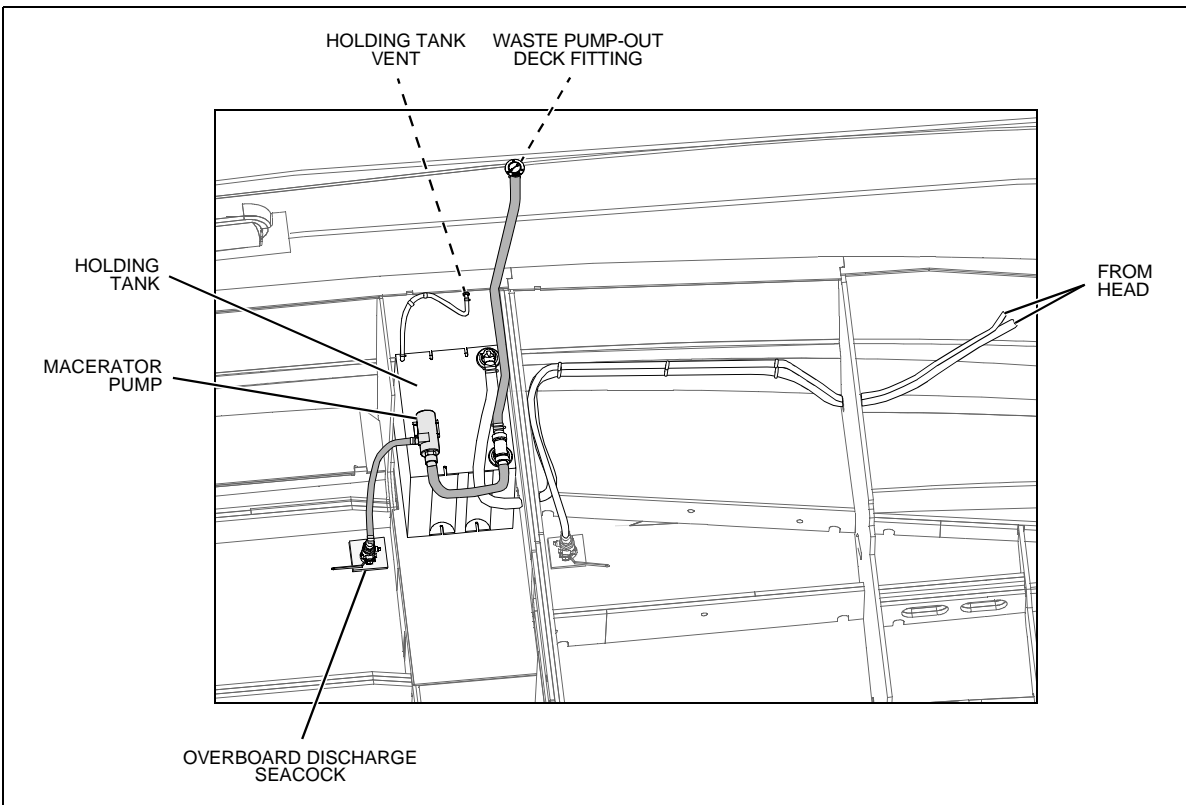

To use the macerator to pump waste directly into the water (where regulations permit):

1. **Open** the underwater discharge seacock.
2. Press both macerator switches at the same time to run the pump. **Do not** continue running the macerator if the waste holding tank is empty.
3. **Close** the underwater discharge seacock when you are done pumping.

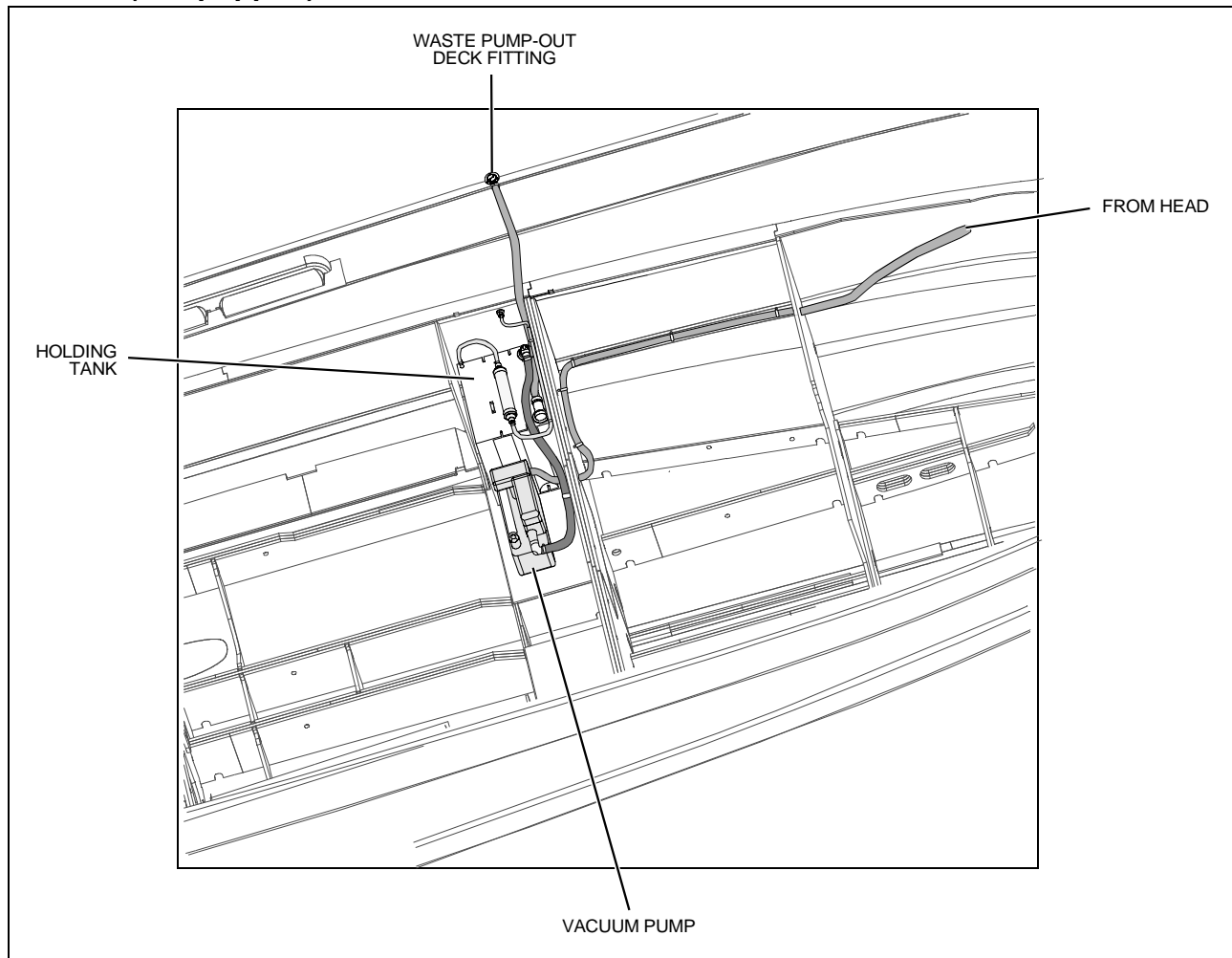
**VacuFlush (If Equipped)**

- The VacuFlush head system uses a vacuum pump and freshwater from the water tank to flush waste from the toilet into the holding tank.
- The holding tank is plumbed to a waste fitting on the deck for dockside pump-out.
- For winterizing instructions, refer to the VacuFlush head, operation and maintenance manual.

## Chapter 7: Deck Equipment

---

### Cleats

 <b>WARNING!</b>
<p><b><i>PERSONAL INJURY and /or PRODUCT or PROPERTY DAMAGE HAZARD!</i></b></p> <ul style="list-style-type: none"> <li>• <b><i>NEVER</i></b> lift the yacht using the cleats.</li> </ul>

Carefully read the section on towing in the *Cruiser & Yacht Owner's Manual Supplement* **before** towing anything behind the yacht or having the yacht towed by another vessel.

### Windlass (If Equipped)

 <b>CAUTION!</b>
<p><b><i>PRODUCT DAMAGE HAZARD!</i></b></p> <ul style="list-style-type: none"> <li>• <b><i>DO NOT</i></b> pull the yacht to the anchor using the windlass or continue to run the windlass if it has stalled or is overloaded.</li> </ul>

- Your yacht may feature an anchor windlass.
- Read and follow the manufacturer's instruction manual **before** using the anchor windlass for the first time.
- The windlass can be controlled from a switch at the helm or from the deck foot switches.
- Make sure that the windlass breaker is turned on **before** using the anchor windlass.
- To haul the anchor, use engine power (**not** the windlass) to move the yacht to, and directly above, the anchor.
- Use the windlass to dislodge the anchor from the bottom by pulling it straight up.
- Make sure the anchor is secured **before** getting underway.

## Canvas



### CAUTION!

Take down and securely stow the convertible top, side curtains and back cover *before* transporting your yacht by road.

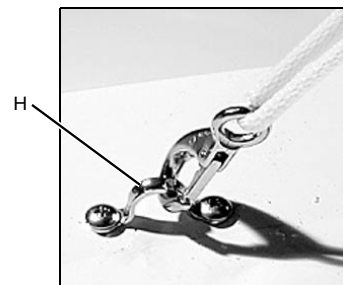
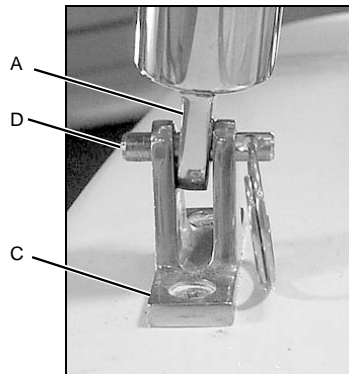
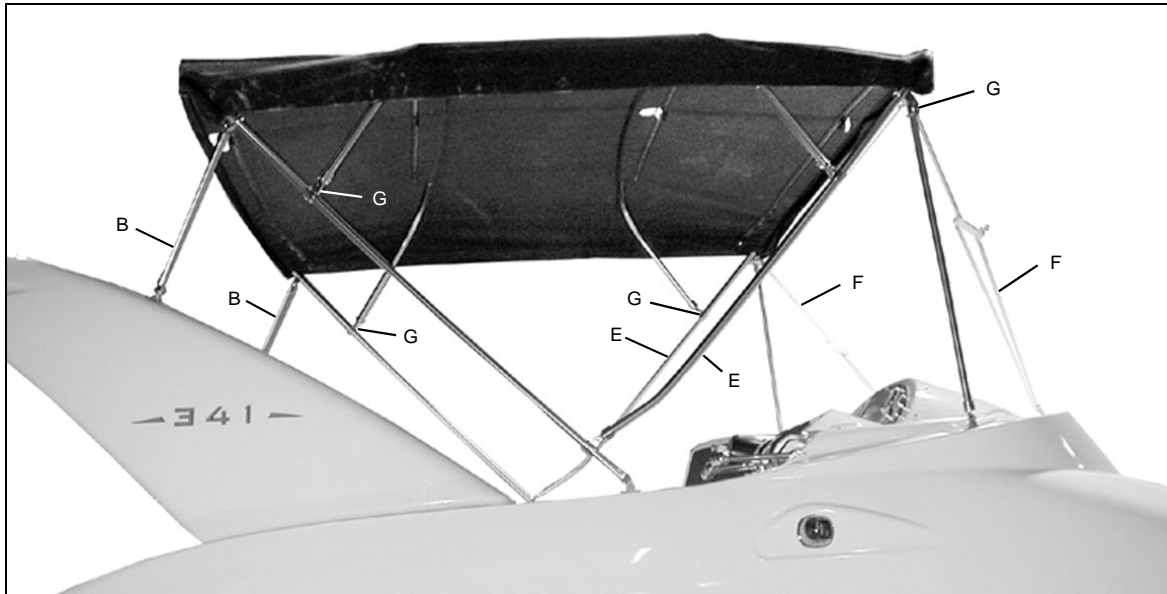

1. Insert the end eyes (A) of the aft braces (B) into the deck hinges (C) and secure with the pins (D).
2. Pull the secondary bows (E) forward and insert the end eyes of the forward braces into the deck hinges and secure with the pins.
3. Tie the hold down straps (F) to the forward jaw slides (G) then hook the hold down straps to the deck loops (H).
  - The jaw slides should *not* need to be adjusted.
  - However, if you think the jaw slides need to be adjusted, obtain the measurements from your selling dealer.

## Chapter 8: Appliances & Entertainment Systems

### NOTICE

*Always keep an approved ABC-type fire extinguisher in galley area.*

*All* appliances and entertainment systems installed on your yacht come with their own manuals. These manuals contain detailed instructions and important safeguards. Thoroughly read and understand these manuals *before* using your yacht's appliances and entertainment systems.

- Make sure the AC breaker is turned **On** for the appliance you wish to use.

### Refrigerator

Your yacht features a 120-volt AC/12-volt DC refrigerator. The refrigerator runs on 12-volt DC power unless 120-volt AC power is being supplied by the shore power *and* the AC refrigerator breaker is **On**.

### Electric Stove (If Equipped)





### WARNING!





***BURN/SCALDING and/or FIRE HAZARD!***

- Read the stove's instruction manual *before* using.
- *Always* keep an approved ABC-type fire extinguisher in galley area.
- *Do not* use the stove while underway.
- Any non-cooking devices on or near your stove during use are potential fire hazards!
- ***DO NOT*** touch burners, grates or nearby surfaces as they may be hot even when they are dark in color. Areas near burners and grates may become hot enough to cause burns.
- During and after use, *do not* touch or let clothing or other flammable material come in contact with heated units or areas near the units (burner tops, main frame sides and back, sea rails and pot holders) until they have had sufficient time to cool.

## Propane Stove (If Equipped)

 <b>DANGER!</b>	
	<p style="text-align: center;"><b><i>CARBON MONOXIDE POISONING HAZARD!</i></b></p> <ul style="list-style-type: none"> <li>• The propane stove is a source of dangerous carbon monoxide gas (CO).</li> <li>• <b>BEFORE</b> using the propane stove, <i>Open</i> doors and windows to make sure there is enough fresh air for ventilation.</li> </ul>

 <b>WARNING!</b>	
<ul style="list-style-type: none"> <li>• Open flame cooking appliances consume oxygen, this can cause asphyxiation or death.</li> <li>• Maintain <i>Open</i> ventilation.</li> </ul>	

 <b>WARNING!</b>	
	<p style="text-align: center;"><b><i>BURN/SCALDING and/or FIRE HAZARD!</i></b></p> <ul style="list-style-type: none"> <li>• Read the stove's instruction manual <i>before</i> using.</li> <li>• <i>Always</i> keep an approved ABC-type fire extinguisher in galley area.</li> <li>• <i>Do not</i> use the stove while underway.</li> <li>• Any non-cooking devices on or near your stove during use are potential fire hazards!</li> <li>• <b>DO NOT</b> touch burners, grates or nearby surfaces as they may be hot even when they are dark in color. Areas near burners and grates may become hot enough to cause burns.</li> <li>• During and after use, <i>do not</i> touch or let clothing or other flammable material come in contact with heated units or areas near the units (burner tops, main frame sides and back, sea rails and pot holders) until they have had sufficient time to cool.</li> </ul>

## Propane System (If Equipped)

! **DANGER!**



**DANGER**  
CARBON MONOXIDE

***CARBON MONOXIDE POISONING HAZARD!***

- Propane appliances are potential sources of dangerous carbon monoxide gas (CO).
- *Do not* use propane appliances without adequate ventilation.

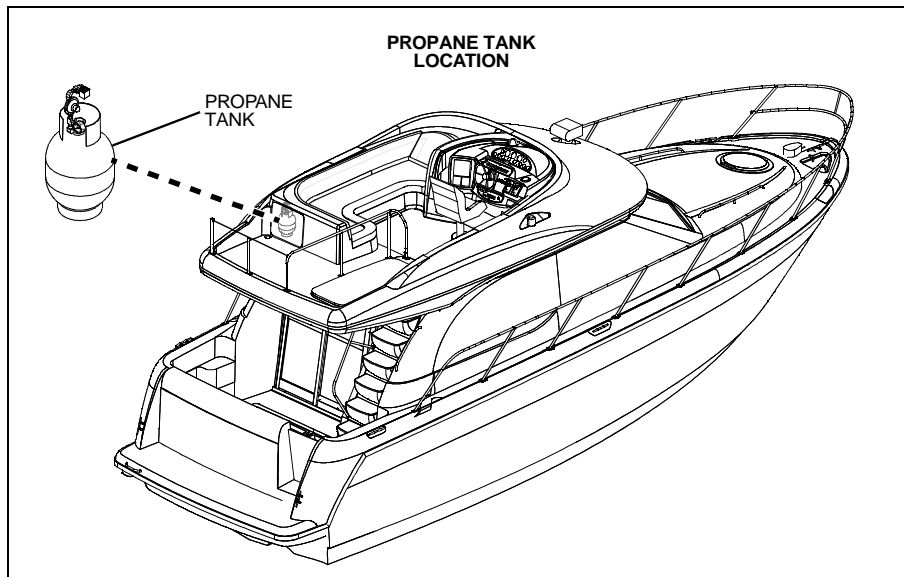

## Audio & Visual Equipment

**NOTICE**

AM radio reception may be impaired anytime the engine is running.



## Dockside Television & Telephone Inlet

- If you want to watch cable TV or use a telephone, plug a dockside source into the TV/telephone inlet.

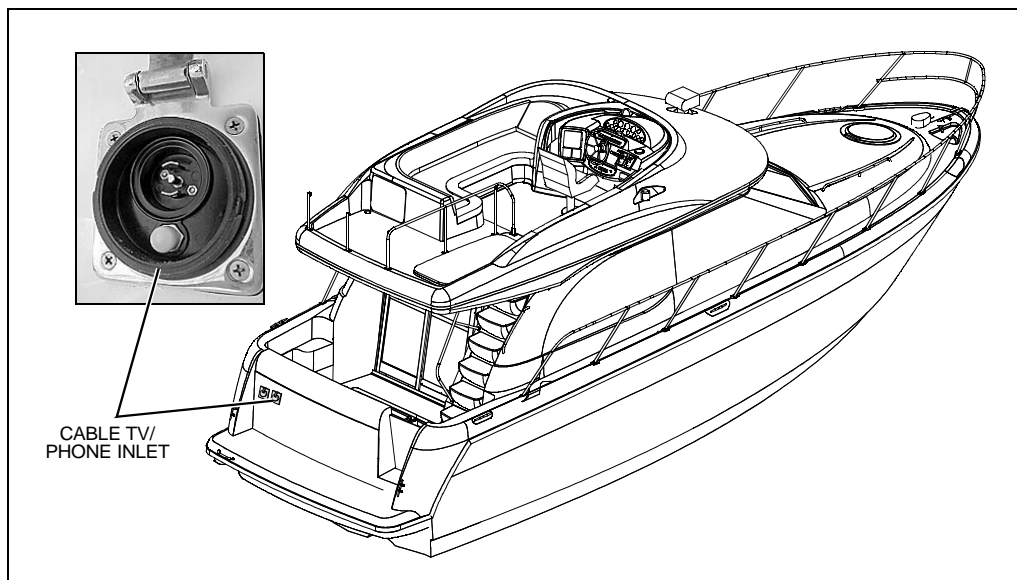

## Chapter 9: Lights

---

### Care and Maintenance

All of the lights installed on your yacht are of top quality, but you should be aware that failure may periodically occur for a variety of reasons:

1. There may be a blown fuse - *replace the fuse.*
2. The bulb may be burned out - *carry spare bulbs for replacement.*
3. A wire may be damaged or may have come loose - *repair as required.*
4. The bulb base may be corroded - *clean the base and coat it with non-conductive electrical lubricant.*

### Interior & Exterior Lights



#### CAUTION!

- **Be conservative in the use of battery power.**
- **Prolonged use of cabin interior lights (overnight) will result in a drained battery.**

- The lights are powered by the yacht's 12-volt DC system.
- The battery switch must be in the **On** position for the lights to work.
- There are **On/Off** light switches for different sets of lights on the cabin wall.
- Some individual lights also have a switch on the light.

### Spotlight (If Equipped)

- Your yacht may feature a spotlight on the command bridge.
- The spotlight controls are located at the upper helm station.
- Read the spot light operating instructions **before** using the spotlight.

## Chapter 10: Heating & Air Conditioning

### Air Conditioning System (If Equipped)

**! DANGER!**



***CARBON MONOXIDE POISONING HAZARD!***

Dangerous carbon monoxide gas (CO) can be brought into the boat through the air conditioning system.

**! CAUTION!**

***SYSTEM DAMAGE HAZARD!***

The air conditioning system's seacock *must* be *Opened* before turning *On* the air conditioner and *must* remain *Open* during use.

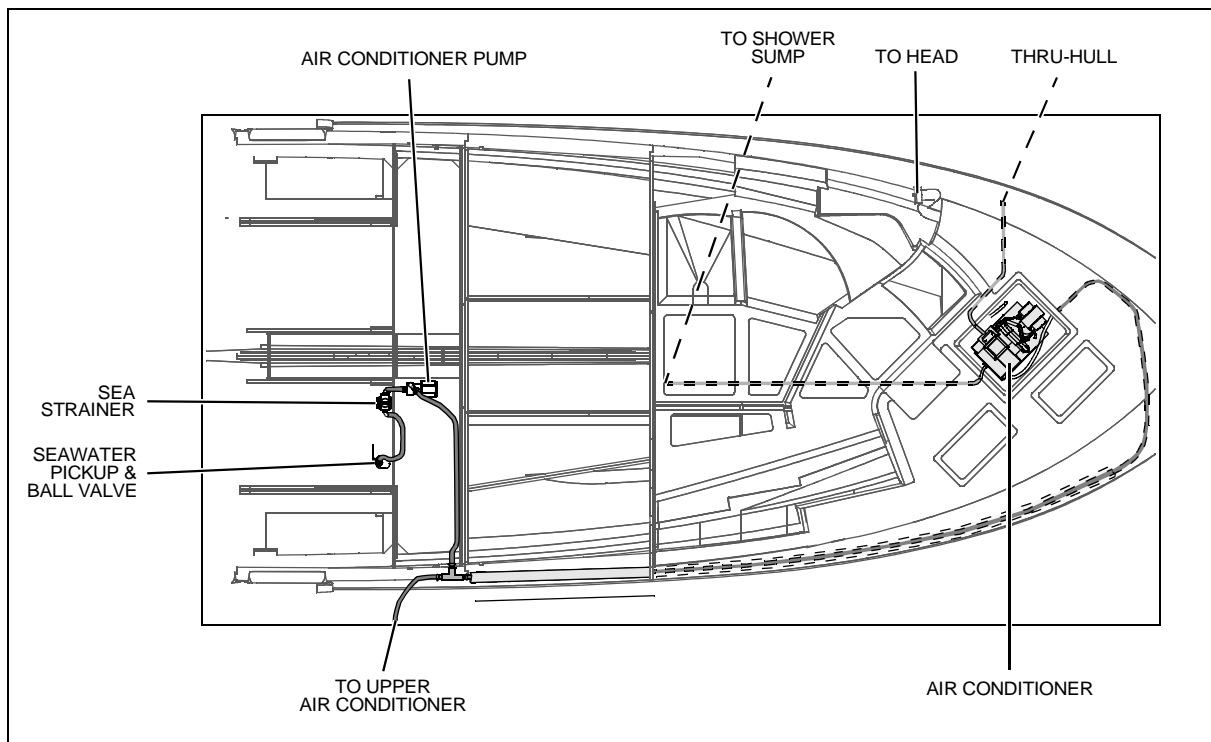

Read the air conditioner manual *before* using the air conditioning system.

- ***Before*** using the air conditioning system, make sure the breakers on the AC main distribution panel are turned ***On*** and make sure the system's seawater pickup seacock is ***Open***. The seacock ***must*** remain ***Open*** anytime the air conditioner is in use.
- The seawater pickup strainer should be checked for debris according to the directions given in the *Seawater Strainer* section of this *Owner's Manual*.

## Electric Heaters (If Equipped)

Your yacht may feature electric cabin heaters. Operating instructions for this system can be found in the manufacturer's instruction manual.

- **Before** using the electric heaters, make sure the breakers on the AC panel are turned **On**.

## Heat Exchanger Cabin Heater (If Equipped)

Your yacht may feature a heat exchanger cabin heater. This heater runs directly off the port engine.

- Make sure the circulation loop shut-off valve is **Open before** using the heater
- Access to the circulation loop shut-off valve is through the floor cutout in the salon.
- For further instructions, read the manufacturer's instruction manual.
- The circuit breaker for the heater fan is on the main DC panel and must be **On** to enable the heater fan's 3-position switch.
- If the heater's circulation loop is **Open** and the port engine is running, the heater **will** radiate heat even with the fan turned **Off**.
- **All** circulation to the heater can be shut **Off** by closing the circulation loop shut-off valve.

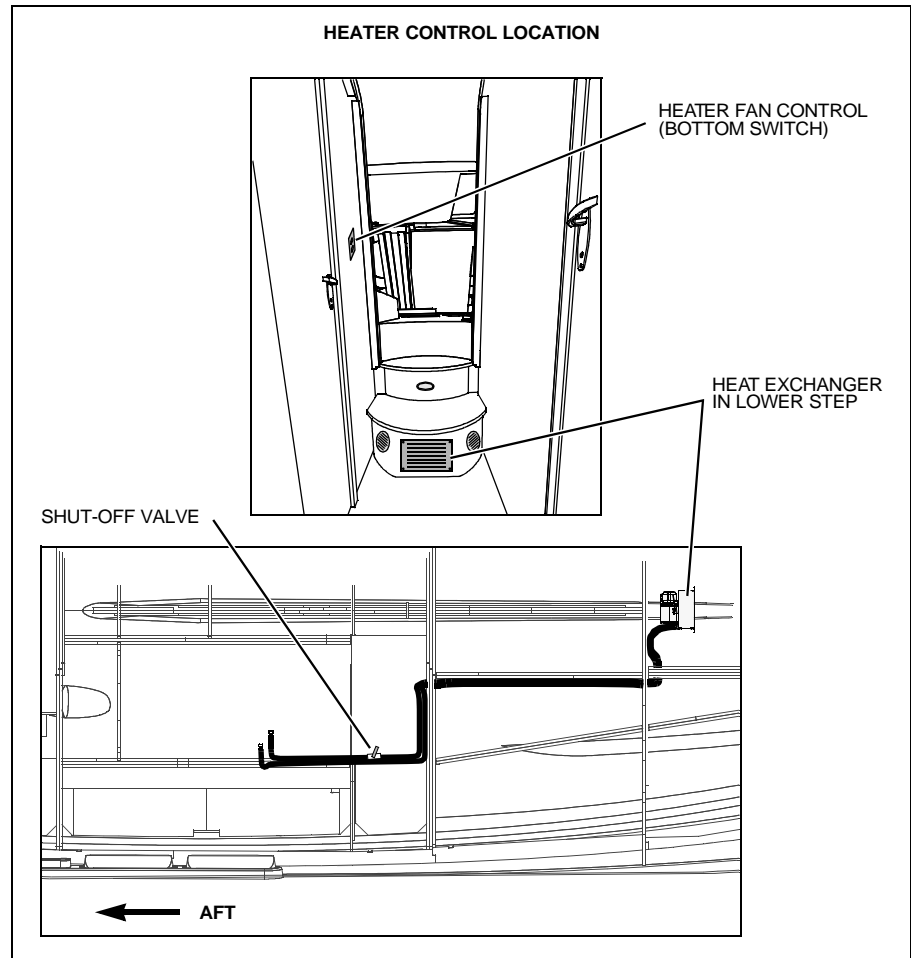

## Chapter 11: Electrical Systems

**⚠ DANGER!**









**EXTREME FIRE, SHOCK & EXPLOSION HAZARD!**

- To minimize the risks of fire and explosion, *NEVER* install knife switches or other arcing devices in the fuel compartments.
- *NEVER* substitute automotive parts for marine parts. Electrical, ignition and fuel system parts were designed and manufactured to comply with rules and regulations that minimize risks of fire and explosion.
- *DO NOT* modify the electrical systems or relevant drawings.
- Have qualified personnel install batteries and/or perform electrical system maintenance.
- Make sure that all battery switches are turned *Off before* performing any work in the engine spaces.

**⚠ WARNING!**

**FIRE & EXPLOSION HAZARD!**

- Fuel fumes are heavier than air and *will* collect in the bilge areas where they can be accidentally ignited.
- Visually and by smell (sniff test), check the engine and fuel compartments for fumes or accumulation of fuel.
- *ALWAYS* run the bilge blowers for at least four minutes prior to engine starting, electrical system maintenance or activation of electrical devices.
- Minimize the danger of fire and explosion by not exposing the batteries to open flame or sparks. *NEVER* smoke anywhere near the batteries.

**⚠ CAUTION!**



**SHOCK & ELECTRICAL SYSTEM DAMAGE HAZARD!**

**NEVER** disconnect the battery cables while the engine is running since it can cause damage to your yacht's electrical system components.

**NOTICE**

Electrical connections are prone to corrosion. To reduce corrosion caused electrical problems, keep *all* electrical connections clean and apply a spray-on protectant that is designed to protect connections from corrosion.

## 12-Volt DC System

### Batteries

The batteries supply electricity for lights, accessories, and engine starting.

The Electrical section of Chapter 8, in the *Cruiser & Yacht Owner's Manual Supplement*, provides battery, care and maintenance instructions.

### Fuses and Circuit Breakers

- Fuses and circuit breakers for engines and main accessory power are on the DC main distribution panel and on the battery switch panel.
- Some equipment may have secondary fuse protection at the unit, behind the battery switch panel or at the batteries.
- Electronics power is provided at the helm station.

### 12-Volt Accessory Outlet

**! CAUTION!**

**DO NOT use the 12-volt accessory outlet with a cigarette or cigar lighter. High temperatures may melt the outlet.**

- Your boat features a 12-volt accessory outlet at the helm.
- The outlet can be used with any 12-volt device which draws 15 amps or less.
- The 12-volt accessory outlet is protected by a 15 amp circuit breaker on the main circuit breaker panel.

### Battery Switch

**! CAUTION!**

- **The parallel switch should be turned *On* only in emergencies.**
- ***Never* disconnect the battery cables or turn *Off* the main battery switches while engines are running as this can cause damage to your boat's electrical components**

- A separate rotary battery switch is provided for each battery.
- The batteries supply electricity for lights, engine and generator starting, as well as power to turn ***On*** accessories.
- Some "Standby Loads", such as the CO monitors, the automatic bilge pumps, and the stereo memory, are ***not*** affected by the battery switch since they are wired directly to the battery (see the *Wiring Diagrams* in this *Owner's Manual* for more details).

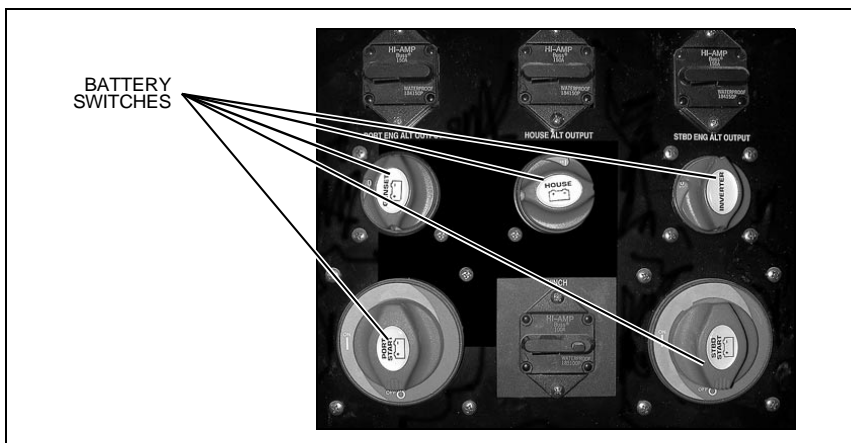

## Alternators

The engine alternators *will* keep the batteries properly charged when running at cruising speeds.

## Battery Charger

 <b>CAUTION!</b>
<b><i>ENGINE &amp; ELECTRICAL SYSTEM DAMAGE HAZARD!</i></b>
<b><i>NEVER run the yacht's engine and the battery charger at the same time.</i></b>

 <b>CAUTION!</b>
<b>The battery charging systems (alternator and battery charger) installed on your yacht are designed to charge conventional lead-acid batteries. <i>Before</i> installing gel-cell or other new technology batteries, consult with the battery manufacturer about charging system requirements.</b>

Your yacht features a battery charger. Thoroughly read and understand the battery charger manual *before* using the battery charger for the first time.

- The battery charger *will* charge the yacht's batteries whenever the yacht is plugged into 120V/60Hz shore power and the "BATTERY CHARGER" AC breaker is *On*.
- The battery charger is independent of the battery switch. The battery switches *do not* need to be *On* for proper charging.
- You may use DC powered electrical systems, such as the lights and stereo when the battery charger is *On*, but there *will* be a corresponding drop in charger performance.

## 120-Volt AC System



### CAUTION!

#### **WATER HEATER DAMAGE HAZARD!**

- **DO NOT** turn *On* the water heater AC panel electrical circuit until the water heater tank is **COMPLETELY** filled with water.
- The tank is full if water flows from the tap when the hot water is turned *On* in the galley.
- Even momentary operation in a dry tank *will* damage the heating elements.
- Warranty replacements **WILL NOT** be made on elements damaged in this manner.

### NOTICE

Whether using shore power or generator power, the simultaneous use of several AC components can result in an overloaded circuit. It may be necessary to turn *Off* one or more accessories in order to use another accessory.

- The 120V/60Hz AC system can be energized by shore power.
- The master circuit breakers, located on the AC panel, provide power source selections to AC powered accessories. Individual breakers **must** be turned *On* to supply power to the accessories you wish to use.
- The AC panel may contain inactive circuit breakers for accessories that are **not** available for this model yacht.

### Shore Power



### DANGER!



#### **FIRE, EXPLOSION & SHOCK HAZARD!**

- **DO NOT** alter shore power connectors and use *only* compatible connectors.
- *Before* connecting or disconnecting the shore power cord to your yacht, make sure *all* breakers and switches on the AC master panel are turned *Off*.
- To prevent shock or injury from an accidental dropping of the “hot” cord into the water, **ALWAYS** attach the shore power cord to the yacht inlet first; then to the dockside connection. When disconnecting from shore power, disconnect the shore power cord from the dockside connection first.
- **NEVER** leave a shore power cord connected to the dockside connection only.
- *Only* use shore power cords approved for marine use. **NEVER** use ordinary indoor or outdoor extension cords that are *not* rated for marine use.



### WARNING!



#### **SHOCK & ELECTRICAL SYSTEM DAMAGE HAZARD!**

- Monitor the polarity indicator lights **EVERY TIME** you connect to shore power.
- If a red reversed polarity light turns *On* when you are connecting to shore power, **DO NOT** energize the main breaker switches.
- Instead, **IMMEDIATELY** disconnect the shore power cord (**ALWAYS** from the dockside receptacle first) and notify marina management.



**WARNING!**

**SHOCK & ELECTRICAL SYSTEM DAMAGE HAZARD!**

- Periodically check the shore power cord(s) for deterioration or damage.
- **NEVER** use damaged or faulty cords since the danger of fire and electrical shock exists.
- **DO NOT** pinch shore power cords in doors or hatches, or coil the shore power cord too tightly since these situations can generate enough heat to result in a fire.
- If a shore power cord accidentally becomes immersed in water, **THOROUGHLY** dry the blades and contact slots before reusing.

**CAUTION!**

**ELECTRICAL SYSTEM DAMAGE HAZARD!**

- **NEVER** connect to dockside power outside of North America unless you have purchased the international electrical conversion option.
- The simultaneous use of several AC components can result in an overloaded circuit. It may be necessary to turn *Off* one or more accessories in order to use another accessory.
- Use double insulated or three-wire protected electrical appliances whenever possible.

**NOTICE**

Some dockside installations may be rated less than 30 amps, therefore, you may need to purchase lower amp adapters. Whenever a lower amp adapter is used, however, there *will* be a corresponding drop in supplied power from the dockside system.

- The single shore power 120V/60Hz, AC system (if equipped) features one, 120V/30 amp, shore power receptacle.
- If your yacht is equipped with an air conditioning system, a second (dual) 30 amp inlet has been installed.
- The dual shore power inlets are labeled "LINE 1" and "LINE 2", which corresponds to the "LINE 1" and "LINE 2" master breakers on the AC panel.
- The dual shore power system is designed so that each line is independent of the other except when the AC power transfer switch is used.

## Connecting To Shore Power

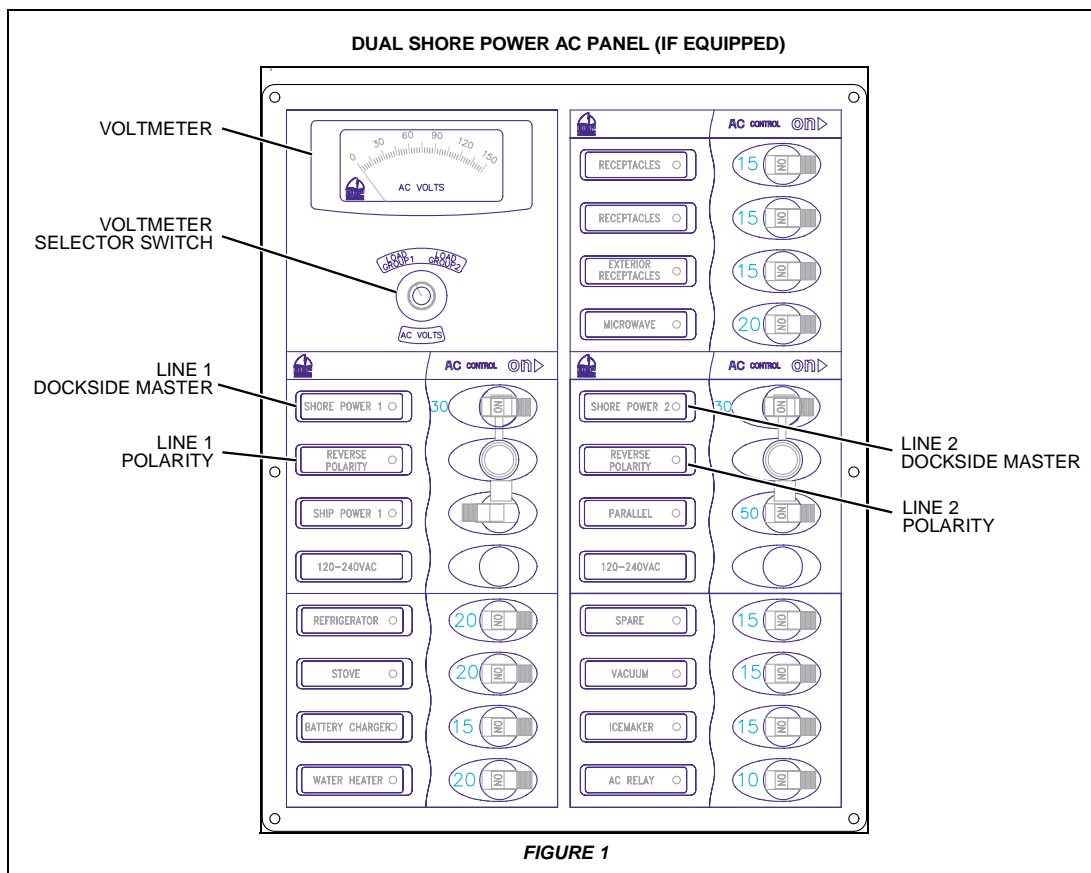
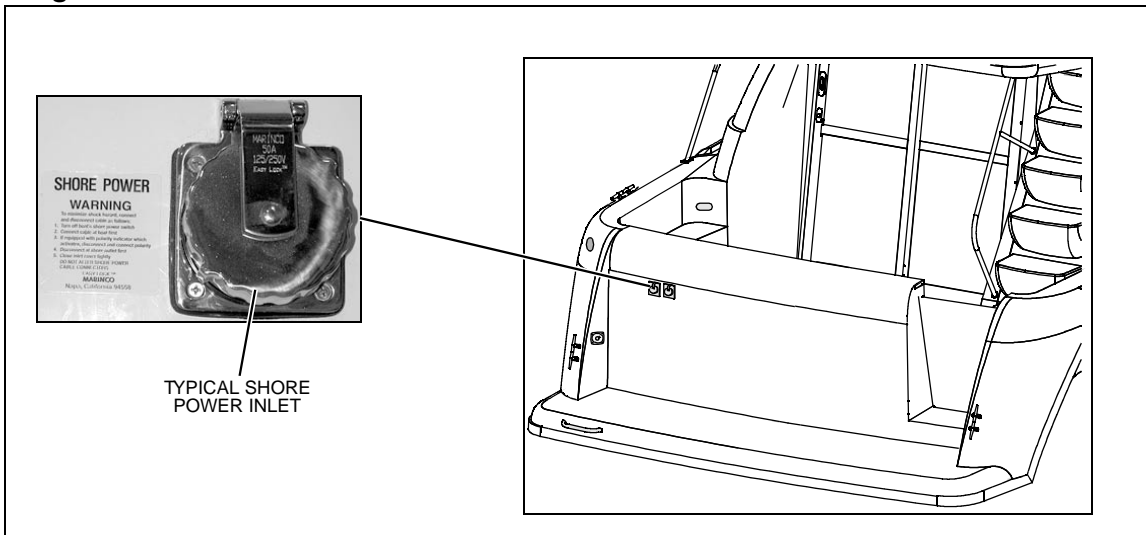

FIGURE 1

1. Review **all** hazard information at the beginning of this section, *Shore Power*.
2. Turn **Off** all breakers and switches on the AC master panel.
3. Attach the shore power cord to the yacht inlet first then to the dockside outlet.

**! WARNING!**

**! SHOCK & ELECTRICAL SYSTEM DAMAGE HAZARD!**

- Monitor the polarity indicator lights *EVERY TIME* you connect to shore power.
- If a reversed polarity light turns *On* when you are connecting to shore power, *DO NOT* turn *On* the main breaker switches.
- Instead, *IMMEDIATELY* unplug the shore power cord (*ALWAYS* from the dockside outlet first) and alert marina management.

4. Switch *On* SHORE POWER 1 and SHORE POWER 2.
5. Turn *On* the master breaker(s) and individual component breakers as required.

### Generator (If Equipped)

**! DANGER!**

**! CARBON MONOXIDE POISONING HAZARD!**

**CO**  
**DANGER**  
CARBON MONOXIDE

- Generators are a source of dangerous carbon monoxide gas (CO). Check the generator exhaust system for leaks *before* each use.

**! WARNING!**

**! FIRE/EXPLOSION HAZARD!**

- Use the bilge blowers for a minimum of four minutes *before* starting the generator.
- Leave the blowers on while the generator is running unless the boat is running at cruising speed.
- Use of the blower system is *NOT A GUARANTEE* that explosive fumes have been removed.
- If you smell any fuel, *DO NOT* start the generator.
- If the generator is already running, *IMMEDIATELY* shut *Off* the generator and *all* electrical accessories and investigate.
- *DO NOT* obstruct or modify the ventilation system.

**! CAUTION!**

**! SYSTEM DAMAGE HAZARD!**

- *Always* make sure the generator's seawater pickup seacock is *Open before and during* the running of the generator.
- *NEVER* use the generator starter for more than 30 seconds.
- If the generator *does not* start, wait at least 30 seconds *before* another start attempt is made.
- After starting the generator, let the generator stabilize *before* turning *On* component breakers on the AC panel.

- The generator can supply 120V/60Hz power to the yacht when it is *not* connected to shore power.
- *Before* using the generator, read the generator operation manual for pre-start checks and break-in procedures.

**Note the following about the generator:**

- Polarity has been established in the installation of the generator(s), therefore the polarity lights will not function in this mode.
- Fuel to run the main generator is supplied from the port fuel tank.
- In addition to servicing the filters attached to the generator(s), the filters/separators (located near the fuel line valves) should be serviced as described in the manufacturer's manual.
- The coolant mixture installed at the factory consists of equal parts of water and antifreeze (Ethylene Glycol).
- The coolant bottle for the generator is located inside the port cockpit floor hatch.
- Check the generator's seawater strainer for leaks and/or debris **before** each use.
- Oil pressure, water temperature, and voltage gauges are provided on the generator control panel, inside the AC/DC cabinet on the port side of the salon. These gauges monitor the engine functions of your generator.

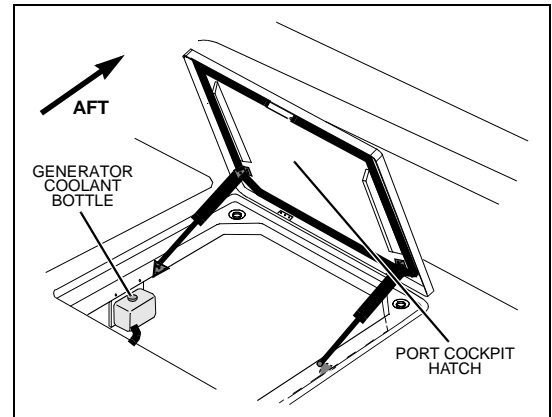
**CAUTION!****SYSTEM DAMAGE HAZARD!**

- **Make sure the generator's seawater pickup seacock is in the *Open* position before and during generator use.**
- **Never run the generator starter for more than 30 seconds. If the generator does not start, wait at least 30 seconds before trying again.**
- **After the generator starts, let the generator stabilize before turning *On* the component breakers on the AC panel.**

**Starting The Generator:**

1. **Open** the generator's seacock valve **before** starting the generator. *Keep the seacock valve **Open** while the generator is running.*
2. Run the bilge blowers (gas generators only) for a minimum of four minutes **before** starting the generator. Leave the blowers on while the generator is running unless your yacht is up to cruising speed.
3. Refer to the generator manual for starting and stopping instructions.

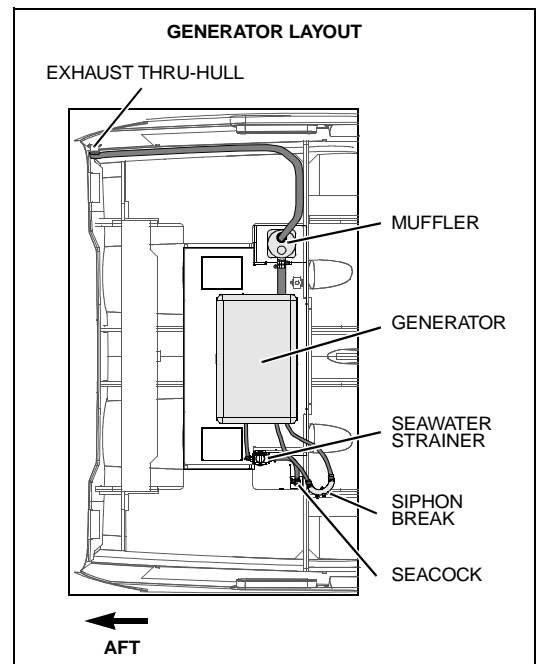

***Inverter Power (If Equipped)***

- The inverter allows the batteries to supply AC power to some accessories when your yacht is *not* connected to shore power.
- The inverter is located in the utility room and can be accessed through the wall cutout in the mid-berth.
- Primary control is from the Inverter Remote Control Panel, located in the main AC/DC cabinet on the port side of the salon.
- Redundant controls are available on the inverter itself. Refer to the inverter manual for detailed inverter operating procedures.
- Activate the AC system under inverter power by switching ***On*** the inverter master breaker (located on the main electrical panel) and pressing the ***On/Off*** switch on the inverter remote control panel.
- The inverter only provides AC power to the accessories that have white breakers on the AC panel.
- Individual breakers ***must*** be activated to supply power to the accessories you wish to use.

# Electrical Routings

## Deck Electrical Harness

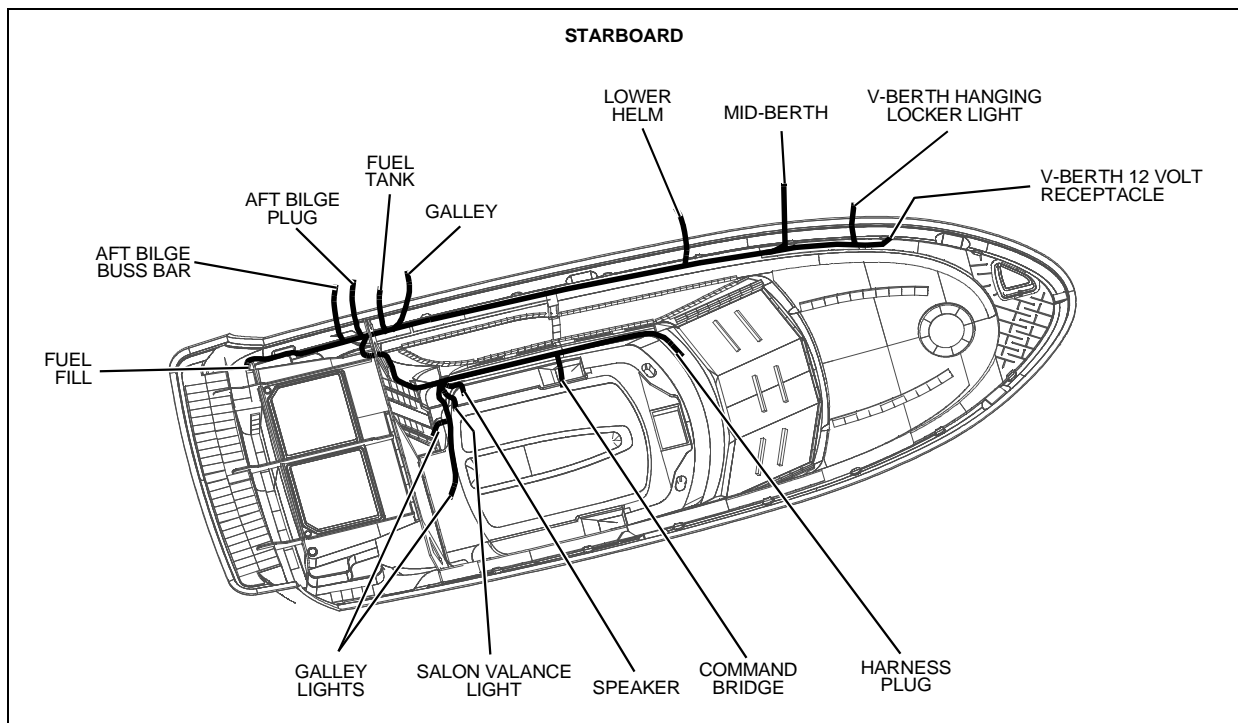
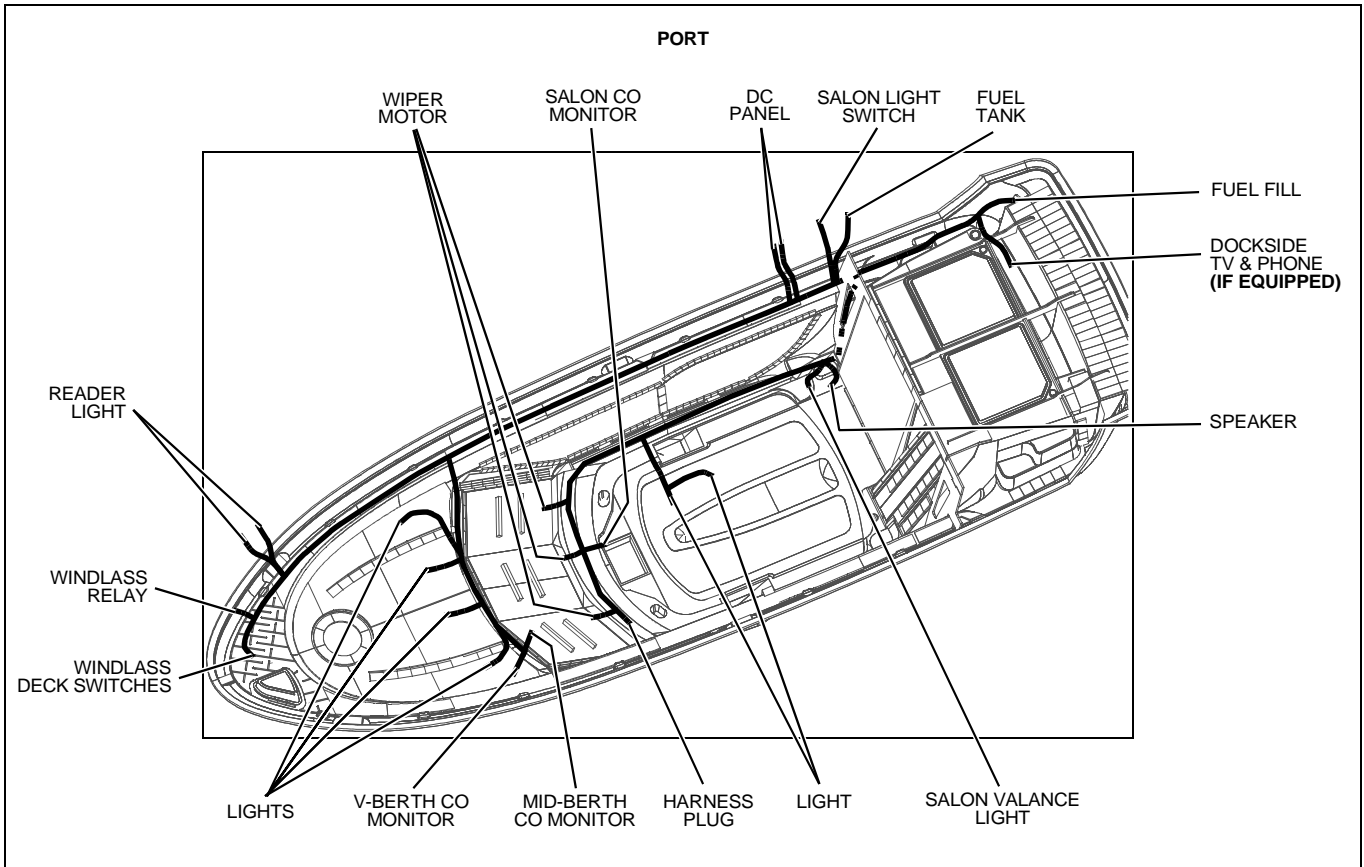

### Command Bridge Harness

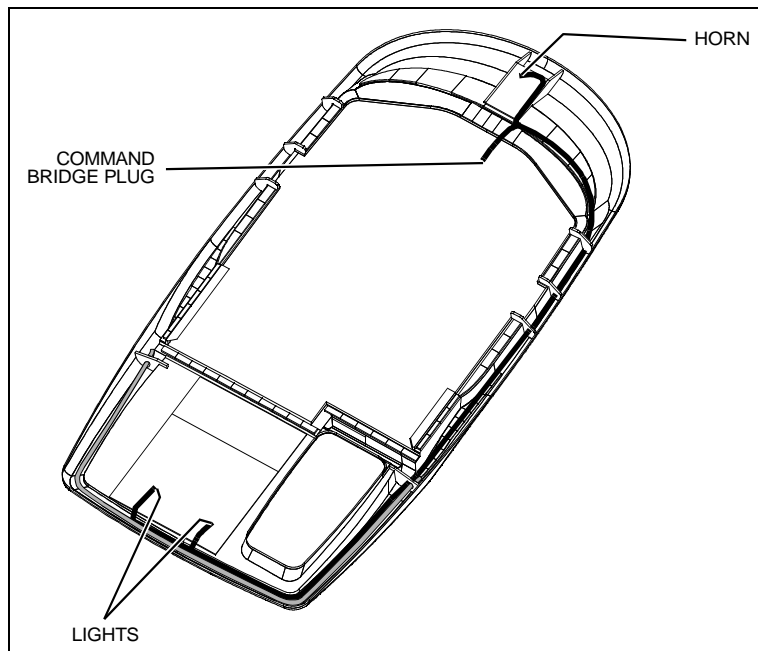
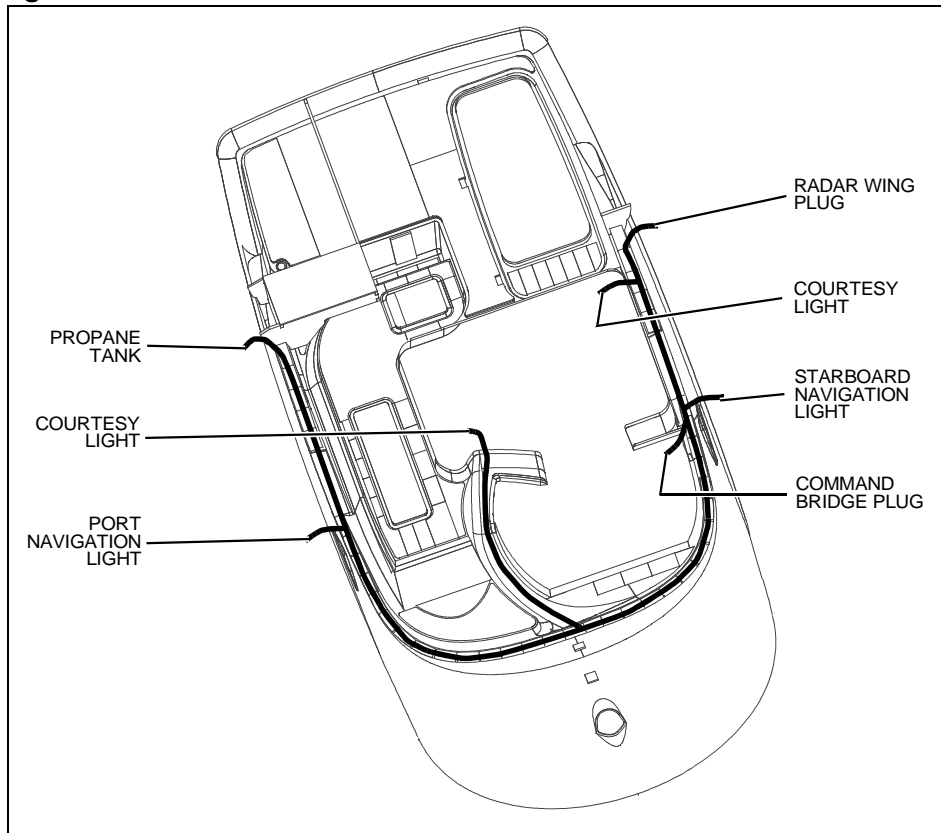

### 12 Volt DC Electrical System

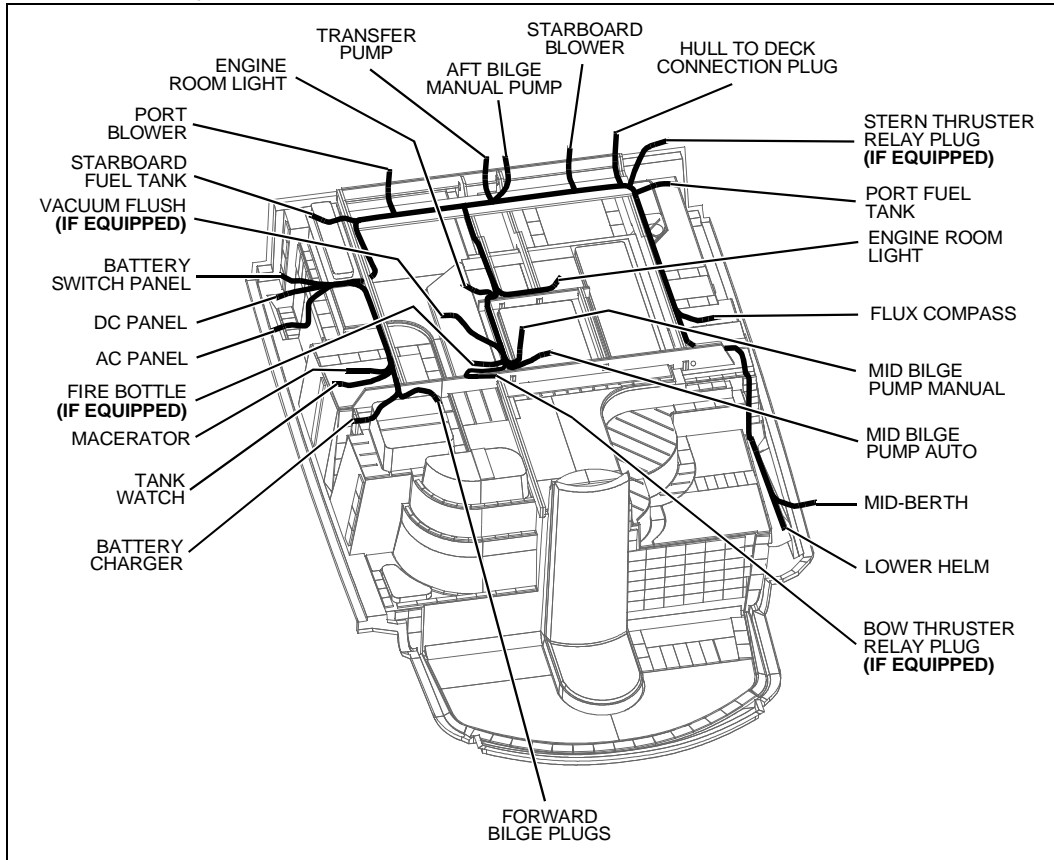

### Power Inverter (If Equipped)

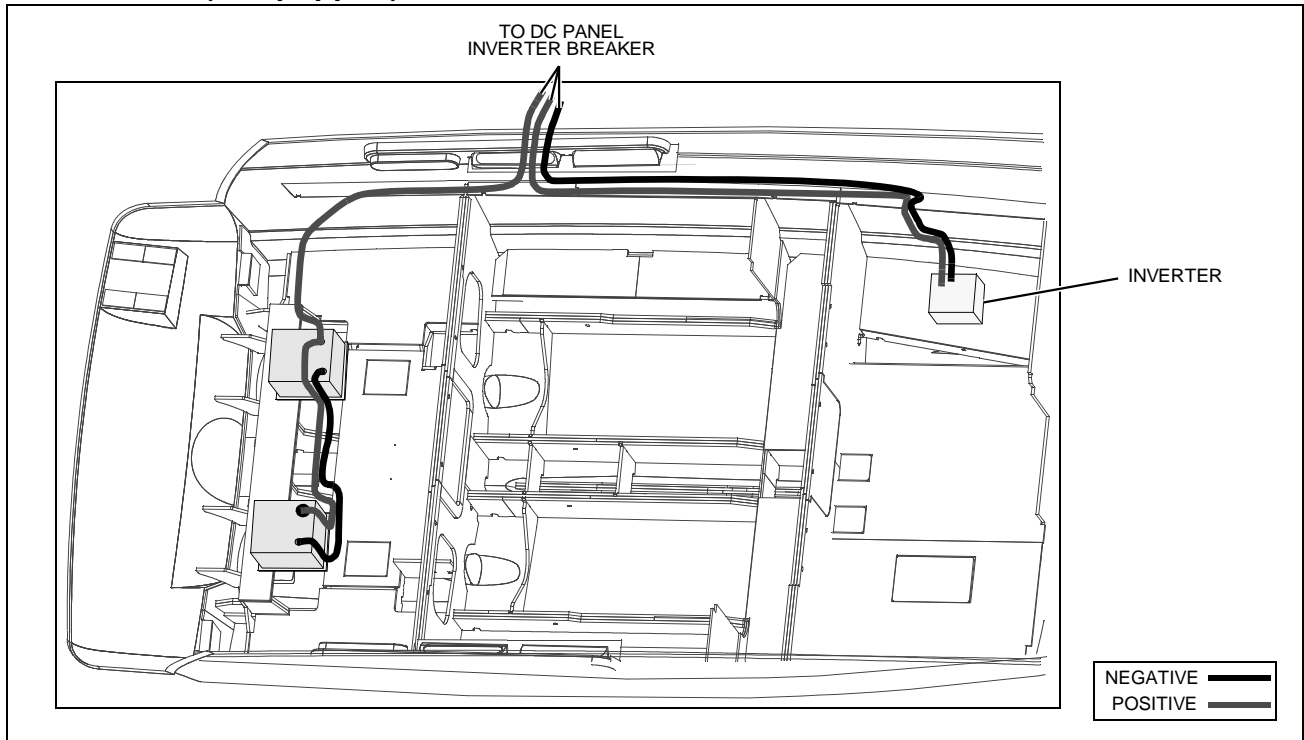



### Dual Thrusters (If Equipped)

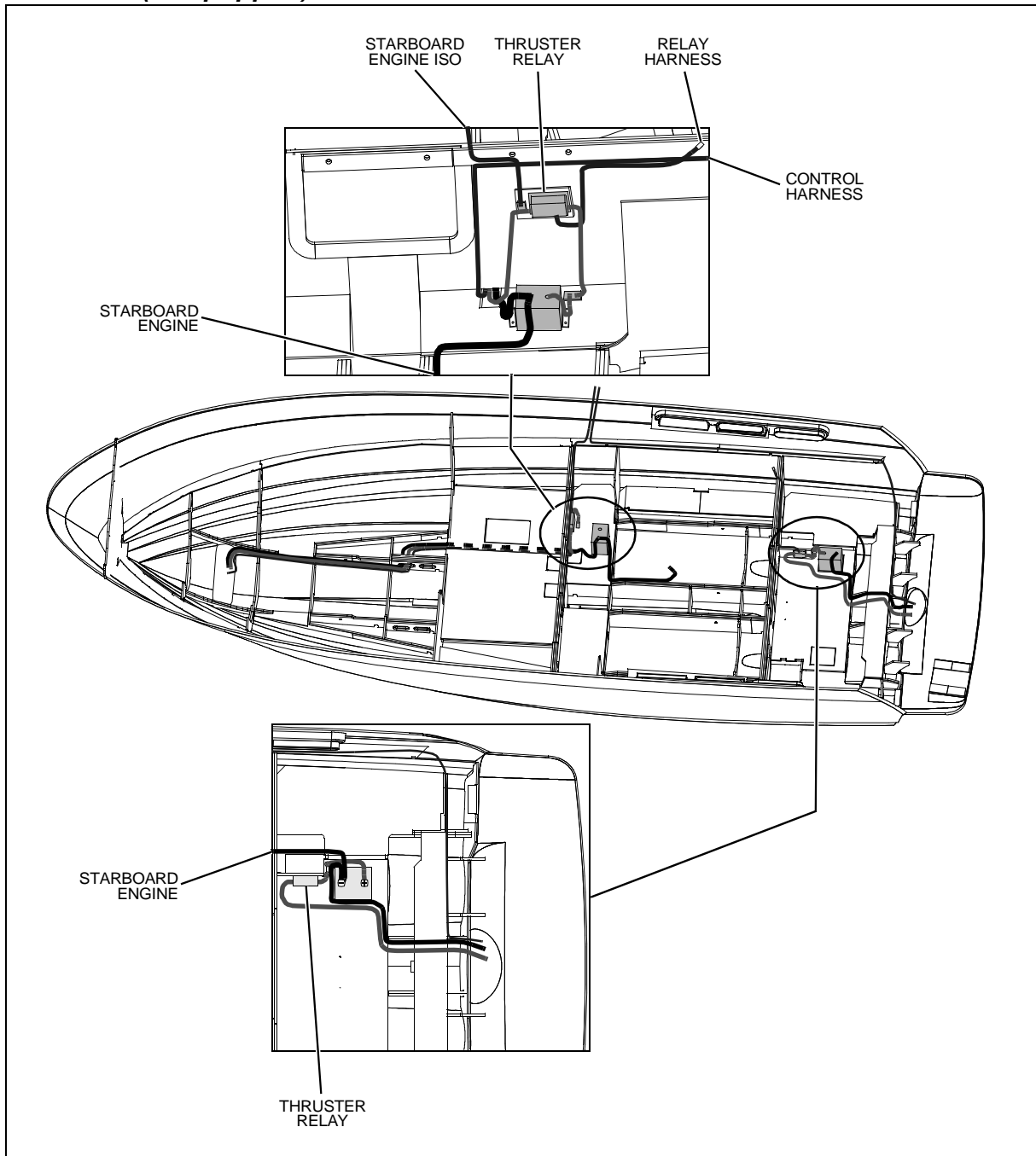

### Battery System

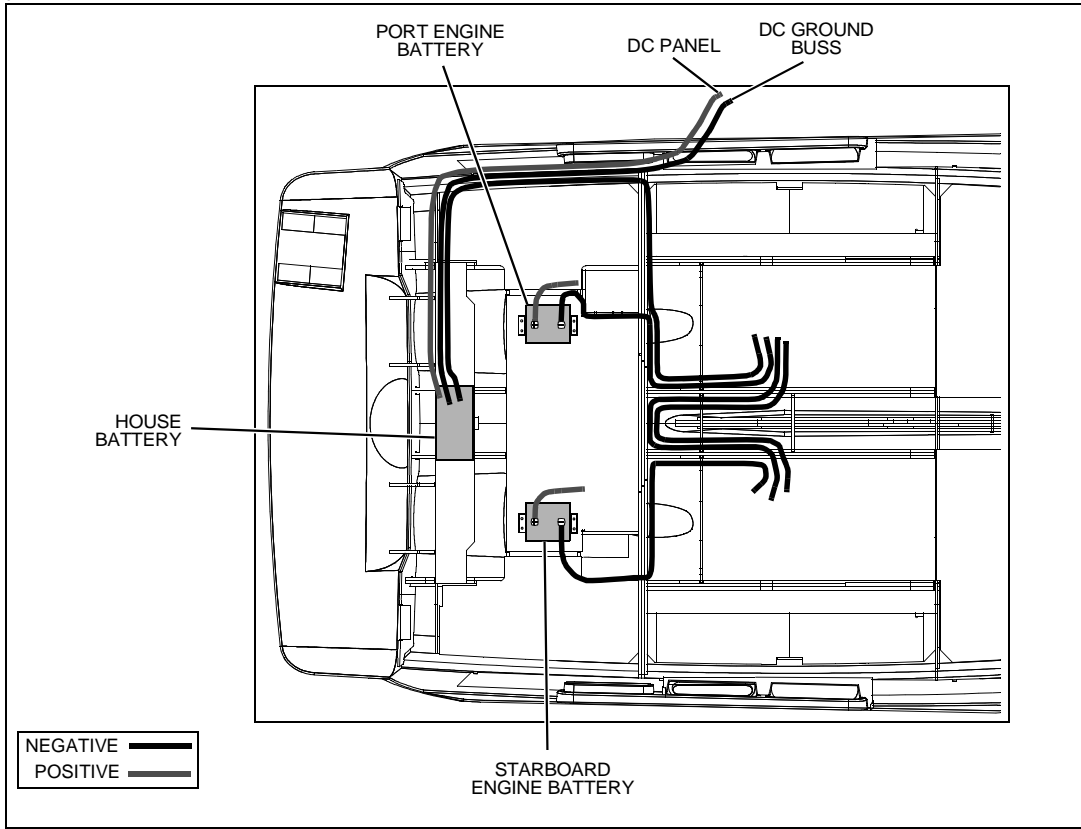

### Bonding Harness

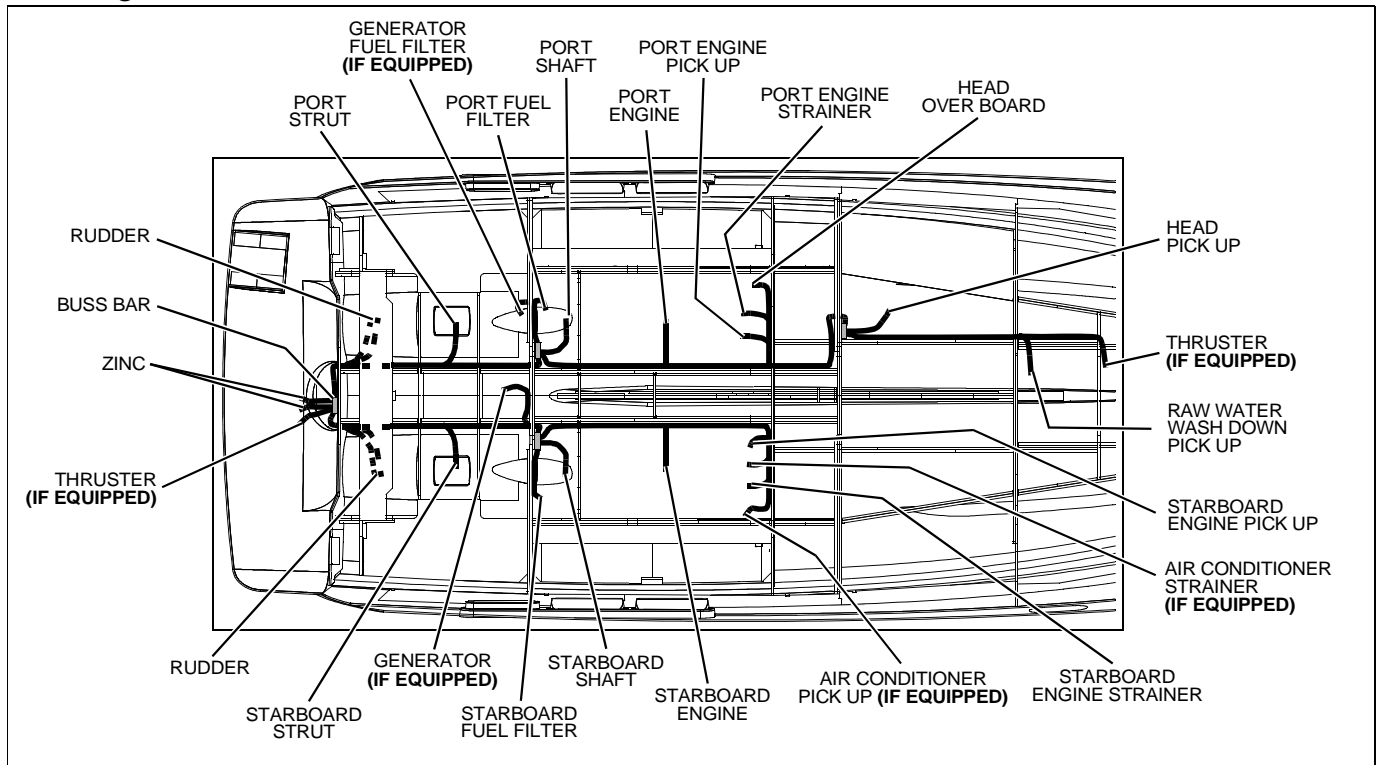

# Wiring Diagrams

## 120-Volt AC Electrical System

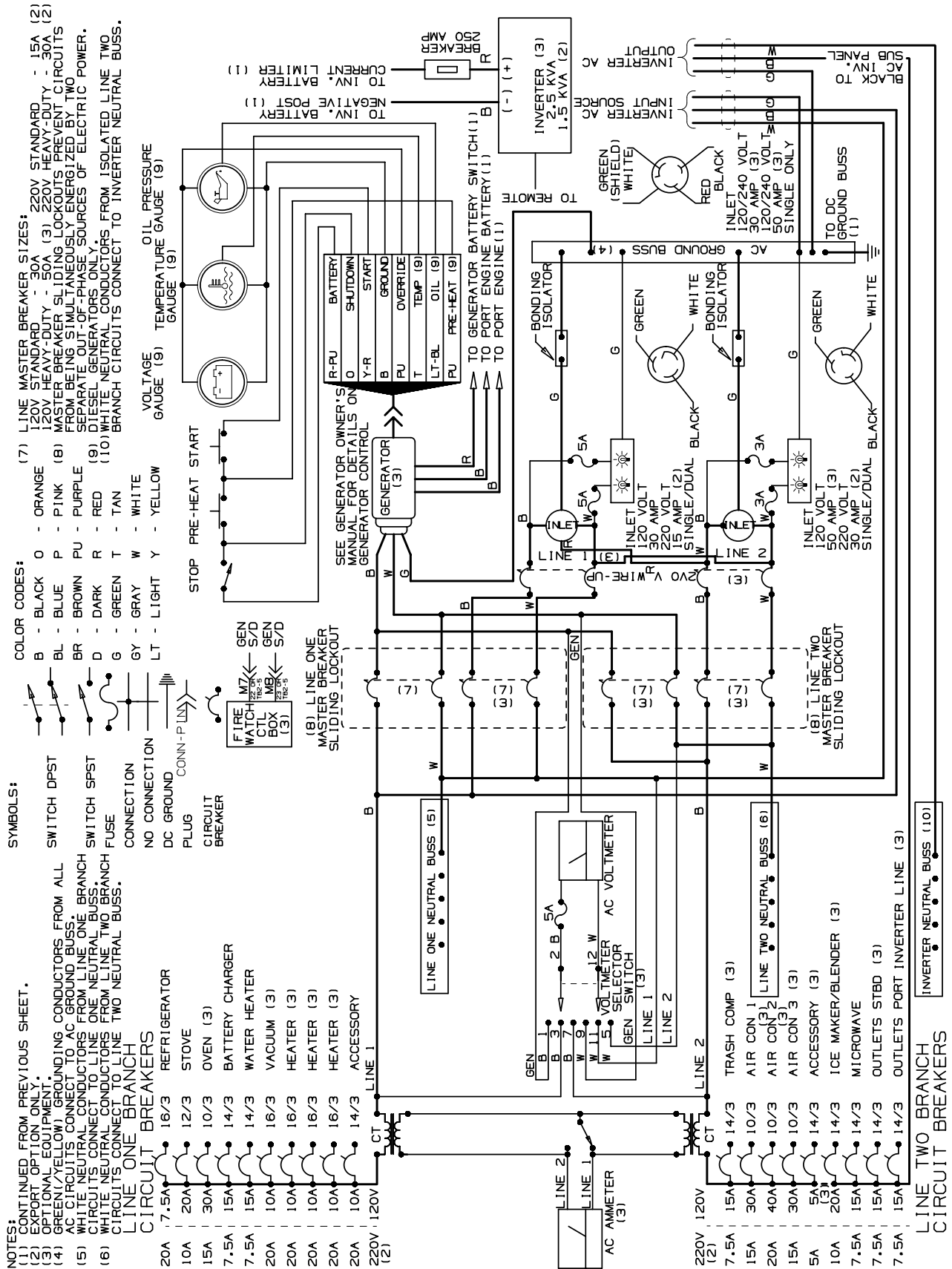

### 12-Volt Auxiliary DC Electrical System

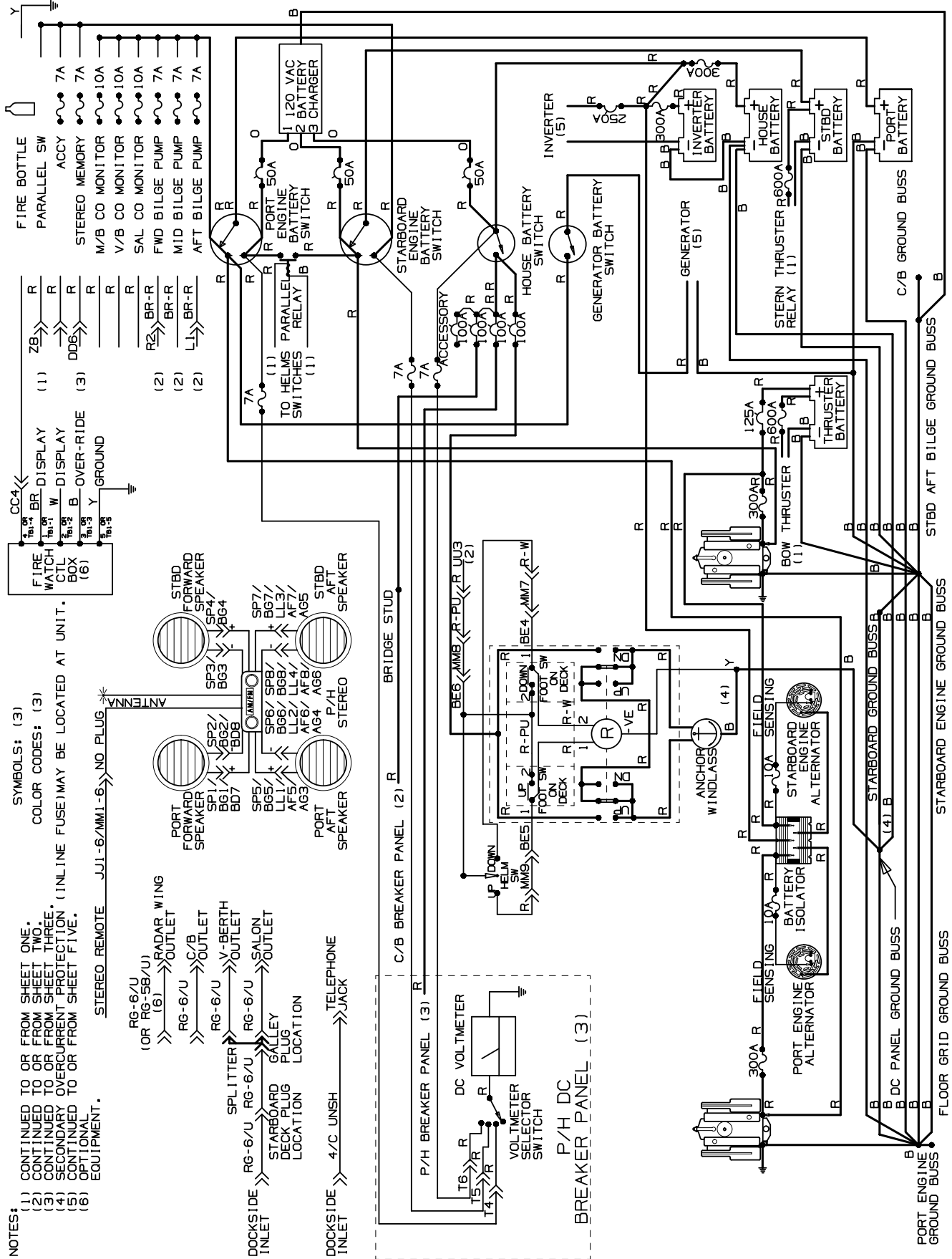

- NOTES:**
- (1) CONTINUED TO OR FROM SHEET ONE.
  - (2) CONTINUED TO OR FROM SHEET TWO.
  - (3) CONTINUED TO OR FROM SHEET THREE.
  - (4) SECONDARY OVERCURRENT PROTECTION. (INLINE FUSE) MAY BE LOCATED AT UNIT.
  - (5) CONTINUED TO OR FROM SHEET FIVE.
  - (6) OPTIONAL EQUIPMENT.
- SYMBOLS: (3)**
- COLOR CODES: (3)**
- STEREO REMOTE JJI-6/MMI-6 → NO. PLUG \*
- RG-6/U (OR RG-58/U) (6) → RADAR WING OUTLET
- RG-6/U → C/B OUTLET
- RG-6/U → V-BERTH OUTLET
- SPLITTER → RG-6/U → STARBOARD GALLEY DECK PLUG LOCATION
- DOCKSIDE INLET → 4/C UNSH → TELEPHONE JACK

### Command Bridge 12-Volt DC Electrical System

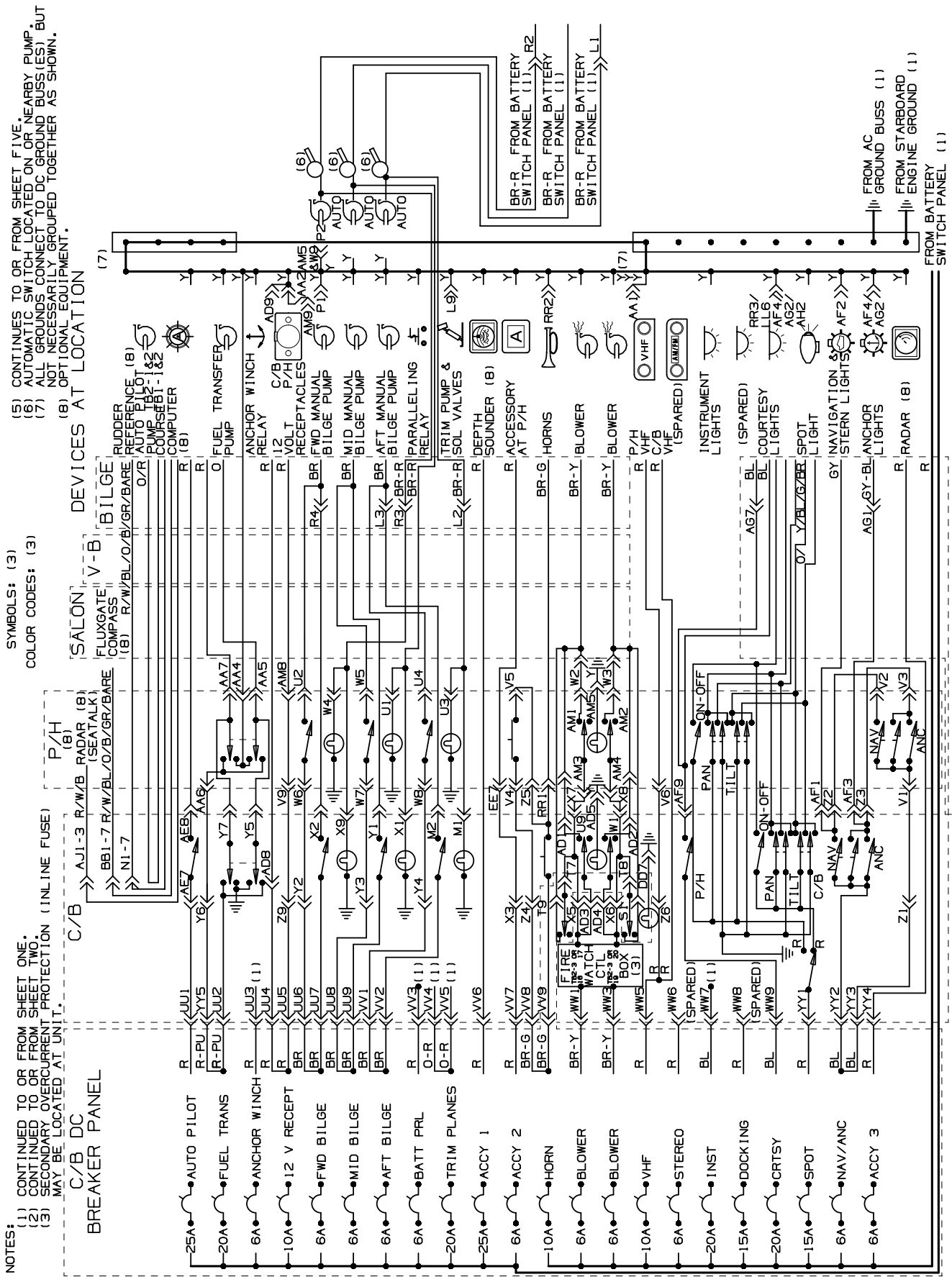

NOTES:

- (1) CONTINUED TO OR FROM SHEET ONE.
- (2) CONTINUED TO OR FROM SHEET TWO.
- (3) SECONDARY OVERCURRENT PROTECTION (INLINE FUSE) MAY BE LOCATED AT UNIT.

SYMBOLS: (3)

COLOR CODES: (3)

(5) CONTINUES TO OR FROM SHEET FIVE.

(6) AUTOMATIC SWITCH LOCATED ON OR NEARBY PUMP.

(7) ALL GROUNDS CONNECT TO DC GROUND BUSSES) BUT NOT NECESSARILY GROUPED TOGETHER AS SHOWN.

(8) OPTIONAL EQUIPMENT.

### 12-Volt DC Breaker Panel System

NOTES:  
 (1) CONTINUED TO OR FROM SHEET ONE.  
 (2) CONTINUED TO OR FROM SHEET TWO.  
 (3) SECONDARY OVERCURRENT PROTECTION (INLINE FUSE) MAY BE LOCATED AT UNIT.  
 (4) CONTINUED TO OR FROM SHEET FOUR.  
 (5) ACCESSORY INLINE FUSES MAY BE LOCATED AT DEVICES OR SOURCES.  
 (6) AUTOMATIC SWITCH LOCATED AT OR NEAR PUMP LOCATION.  
 (7) ALL GROUNDS CONNECT TO DC GROUND BUSS(ES), THOUGH NOT NECESSARILY GROUPED TOGETHER AS SHOWN.

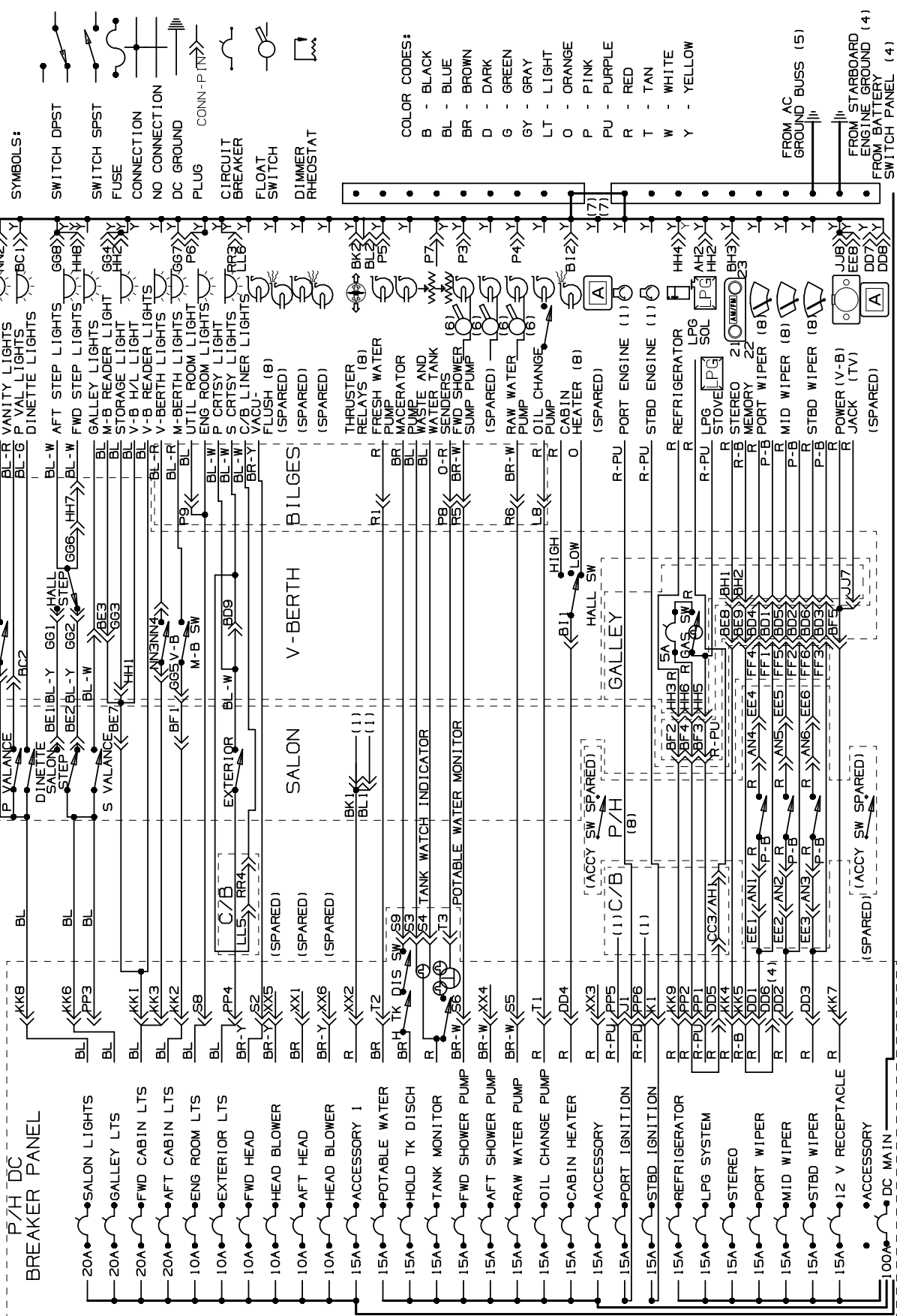



## Important Records

---

### Selling Dealer

\_\_\_\_\_  
Name Of Dealership

\_\_\_\_\_  
Address

\_\_\_\_\_  
Phone/FAX/E-mail

\_\_\_\_\_  
Sales Manager

\_\_\_\_\_  
Service Manager

### Engines

\_\_\_\_\_  
Manufacturer

\_\_\_\_\_  
Model Name/Number

\_\_\_\_\_  
Port Engine Serial Number

\_\_\_\_\_  
Starboard Engine Serial Number

\_\_\_\_\_  
Oil Type/SAE

\_\_\_\_\_  
Quarts per Engine

\_\_\_\_\_  
Filter Type

### Propeller

\_\_\_\_\_  
Manufacturer

\_\_\_\_\_  
Pitch

\_\_\_\_\_  
Model Number

### Generator

\_\_\_\_\_  
Manufacturer

\_\_\_\_\_  
Model Name/Number

\_\_\_\_\_  
Serial Number

\_\_\_\_\_  
Oil Type/SAE

\_\_\_\_\_  
Quarts

\_\_\_\_\_  
Filter Type

### Fuel System

\_\_\_\_\_  
Fuel Capacity

\_\_\_\_\_  
Filter Type

### Plumbing

\_\_\_\_\_  
Fresh Water Tank Capacity

\_\_\_\_\_  
Waste Holding Tank Capacity

### Key Numbers

\_\_\_\_\_  
Cabin

\_\_\_\_\_  
Ignition

\_\_\_\_\_  
Other

\_\_\_\_\_  
Other

### Electronics

\_\_\_\_\_  
Manufacturer

\_\_\_\_\_  
Model Name/Number

\_\_\_\_\_  
Serial Number

\_\_\_\_\_  
Manufacturer

\_\_\_\_\_  
Model Name/Number

\_\_\_\_\_  
Serial Number

\_\_\_\_\_  
Manufacturer

\_\_\_\_\_  
Model Name/Number

\_\_\_\_\_  
Serial Number

\_\_\_\_\_  
Manufacturer

\_\_\_\_\_  
Model Name/Number

\_\_\_\_\_  
Serial Number

\_\_\_\_\_  
Manufacturer

\_\_\_\_\_  
Model Name/Number

\_\_\_\_\_  
Serial Number

\_\_\_\_\_  
Manufacturer

\_\_\_\_\_  
Model Name/Number

\_\_\_\_\_  
Serial Number



# Float Plan

Before going boating, fill out a copy of this float plan (or similar) and leave it with a **reliable** person whom you can depend on to contact the Coast Guard or other rescue organization, if you do not return as scheduled.

## Description of Boat

Registration/Documentation Number		
Length	Make	Type
Hull Color		Trim Color
Fuel Capacity	Engine Type	Number of Engines
Distinguishing Features		
Distinguishing Features		

## Operator of Boat

Full Name		
Male or Female	Age	Health
Address		
Address		
Phone/FAX/E-mail		
Operator's Experience		

## Persons Onboard

Full Name		
Age	Health	Phone Number
Full Name		
Age	Health	Phone Number
Full Name		
Age	Health	Phone Number
Full Name		
Age	Health	Phone Number
Full Name		
Age	Health	Phone Number
Full Name		
Age	Health	Phone Number
Full Name		
Age	Health	Phone Number

### Survival Equipment

Number of PFDs	Flares (Yes/No)	Mirror (yes or no)
Smoke Signals (Yes/No)	Flashlight (Yes/No)	Food (Yes/No)
Water (Yes/No)	Anchor (Yes/No)	Raft/Dinghy (Yes/No)
Paddles (Yes/No)	EPIRB (Yes/No)	Other
Other	Other	Other
Marine Radio (Yes/No)	Type	Frequencies

### Vehicle Description

Make	Model
Color	License Number
Where is the Vehicle Parked?	

### Trip Expectations

Departing From	
Departure Date	Departure Time
Stopover 1	
Arrive No Later Than: Date	Arrive No Later Than: Time
Stopover 2	
Arrive No Later Than: Date	Arrive No Later Than: Time
Stopover 3	
Arrive No Later Than: Date	Arrive No Later Than: Time
Stopover 4	
Arrive No Later Than: Date	Arrive No Later Than: Time
Stopover 5	
Arrive No Later Than: Date	Arrive No Later Than: Time
Stopover 6	
Arrive No Later Than: Date	Arrive No Later Than: Time
Final Destination Port (If Different Than Home Port)	
Arrive No Later Than: Date	Arrive No Later Than: Time

**If not returned by the date and time listed above, call the Coast Guard or other local authority.**

Coast Guard Phone Number
Local Authority Phone Number











**MERIDIAN™**  
**YACHTS**

A subsidiary of the Brunswick Boat Group

████████████████████ | part # 1746006